

# POTEC OPERATION MANUAL

AUTO LENSMETER PLM-8000



# IMPORTANT NOTICE

This product may malfunction due to electromagnetic waves caused by portable personal telephones, transceivers, radio-controlled toys, etc. Be sure to avoid having objects such as, which affect this product, brought near the product.

The information in this publication has been carefully checked and is believed to be entirely accurate at the time of publication. POTEK assumes no responsibility, however, for possible errors or omissions, or for any consequences resulting from the use of the information contained herein.

Upon request, circuit diagrams, component part lists, descriptions, calibration instructions, or other information will be provided to assist service personnel to repair parts of the equipment that are designated by POTEK as repairable by service personnel.

POTEK reserves the right to make changes in its products or product specifications at any time and without prior notice, and is not required to update this documentation to reflect such changes

---

© 2017 POTEK Co., Ltd.

40-4, Techno 2-ro, Yuseong-gu, Daejeon, 34015, Korea

All rights reserved.

Under copyright laws, this manual may not be copied, in whole or in part, without the prior written consent of POTEK.

# SAFETY INFORMATION

If you see any warnings or cautions printed on the warning labels, follow the safety instructions in this manual. Ignoring such cautions or warnings while handling the product may result in injury or accident. Be sure to read and fully understand the manual before using this product.

Keep this manual in easy-to-access place.

## For EU Countries

The following mark, the name & address of the EU Representative shows compliance of the instrument with **Directive 93/42/EEC**.













**EU Representative:**

**Medical Device Safety Service GmbH**  
 iffgraben 41, D-30175  
 Hannover, Germany

### Symbols marked on the Instrument

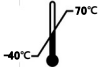
Symbol	Description
~	Alternating current
	Protective earth (ground)
I	On (power: connection to the mains)
O	Off (power: disconnect to the mains)
	Year of manufacture
	Manufacturer
	Authorized Representative in the European Community
	Serial no.
	Follow operating instructions
	the instructions for use in the operation manual

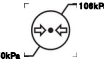











	<p>Keep dry</p>
	<p>This way up</p>
	<p>Handle with care</p>
	<p>Fragile</p>
	<p>Do not build up more than 4 boxes</p>
	<p>Do not use hand-hooks</p>
	<p>Refer to instruction manual</p>
	<p>This indicates hazardous situations which may result in crush your hand</p>
	<p>Disposal of your old appliance</p> <ul style="list-style-type: none"> <li>● When this crossed-out wheeled bin symbol is attached to a product it means the product is covered by the European Directive 2012/19/EU (effective since 14.02.2014).</li> <li>● All electrical and electronic products should be disposed of separately from the municipal waste stream via designated collection facilities appointed by the government or the local authorities.</li> <li>● The correct disposal of your old appliance will help prevent potential negative consequences for the environment and human health.</li> <li>● For more detailed information about disposal of your old appliance, please contact your city office, waste disposal service or the shop where you purchased the product</li> </ul>
	<p>Temperature between - 40°C~ 70°C</p>
	<p>Humidity between 10%RH ~ 95%RH</p>
	<p>Air pressure between 50kPa ~ 106kPa</p>









## General Safety Information

If you see any warnings or cautions printed on the warning labels, follow the safety instructions in this manual. Ignoring such cautions or warnings while handling the product

may result in injury or accident. Be sure to read and fully understand the manual before using this product.

Keep this manual in easy-to-access place.

Caution Sign	Description
 <b>WARNING</b>	This indicates a potentially hazardous situation which could result in death or serious injury to you or others.
 <b>CAUTION</b>	This indicates hazardous situations which may result in minor injury to you or others, or may result in machine damage.
<b>NOTE</b>	This is used to emphasize essential information. Be sure to read this information to avoid incorrect operation.
 <b>WARNING</b>	Only operate the instrument with the power supply indicated on the rating plate. Otherwise, it may result in fire or electric shock.
 <b>WARNING</b>	Be sure to turn OFF the power switch before connecting or disconnecting the cables. Also, do not handle them with wet hands. Otherwise, you may get an electric shock that may result in death or serious injury.
 <b>WARNING</b>	Never disassemble or modify this instrument because it may result in fire or electric shock. Also, since this instrument incorporates high-voltage parts and other hazardous parts, touching them may cause death or serious injury.
 <b>WARNING</b>	Should any of the following occur, immediately turn OFF the power switch, unplug the power cable from the AC outlet, and contact the dealer or the agent who/where you purchase this instrument. <ul style="list-style-type: none"> <li>● When there is smoke, strange odor or abnormal sound.</li> <li>● When liquid has been spilled into the instrument or a metal object has entered through an opening.</li> <li>● When the product has been dropped or its housing damaged.</li> </ul>
 <b>CAUTION</b>	This instrument is shipped with a grounding type power cable. To reduce the risk of electric shock, always plug the cable into a grounded power outlet.
 <b>CAUTION</b>	Do not use the device simultaneously with other electronic equipment to avoid electromagnetic interference with the operation of the device.
 <b>CAUTION</b>	Do not use the device near, on, or under other electronic equipment to avoid electromagnetic interference with the operation of the device.
 <b>CAUTION</b>	Do not use the device simultaneously with portable and mobile radio frequency communication systems because it may have an adverse effect on operation of the device.
 <b>CAUTION</b>	Do not use cables and accessories that are not specified for the device because that may increase the emission of electromagnetic waves from the device or the system and decrease the immunity of the device to electromagnetic disturbance.
 <b>CAUTION</b>	Do not position ME equipment to make it difficult to operate the disconnection device when an appliance coupler or separable plug is used as isolation places.

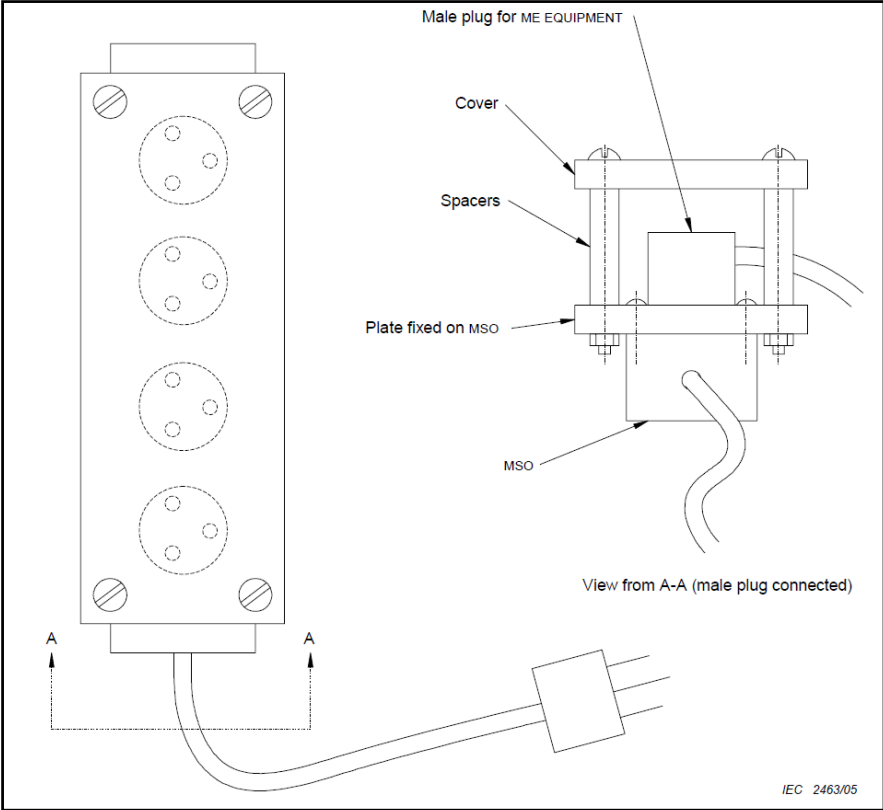
<p> CAUTION</p>	<p>Do not place your fingers between the body and LCD. Otherwise, hand or fingers may be hurt.</p>
<p> CAUTION</p>	<p>During UV transmittance measurement, ultraviolet rays are emitted from the LED source.</p>
<p> CAUTION</p>	<p>During Blue transmittance measurement, blue rays are emitted from the LED source.</p>
<p> CAUTION</p>	<p>Do not place the multiple socket-outlet for PLM-8000 system on the floor in order to prevent liquid penetration and damage to the product.</p>
<p> CAUTION</p>	<p>PLM-8000 system shall not be connected with additional multiple socket-outlets or extension cords in addition to a designated single multiple socket-outlet.</p>
<p> CAUTION</p>	<p>Maximum permissible load of each socket-outlet used for the PLM-8000 system, shall not be less than 100VA.</p>
<p> CAUTION</p>	<p>If non-medical electrical equipment (e.g. Video monitor, IT equipment, etc.) that may be connected with PLM-8000 are, directly connected to the wall socket-outlets, high touch current may flow since the earth continuity is not ensured.</p>
<p> CAUTION</p>	<p>Multiple socket-outlet should be a grounding-type and complied with IEC 60884-1.</p>
<p> CAUTION</p>	<p>Connection of the plug shall be possible only by using the tool. (Refer to the figure below.)</p>
	
<p>NOTE</p>	<p>SAFETY INFORMATION - Accessory equipment connected to the</p>

analog and digital interfaces must be certificated according to the respective IEC standards (e.g. IEC 60950-1 for data processing equipment and IEC 60601-1 for medical equipment). Furthermore all configurations shall comply with the system standard EN 60601-1:2006, Clause 16. Everybody who connects additional equipment to the signal input part or signal output part configures a medical system, and is therefore responsible that the system complies with the requirements of the system standard (IEC 60601-1:2005, Clause 16). If in doubt, consult the technical service department or your local representative.

**NOTE**

Do not expose the device to sunlight or bright light from lighting equipments.

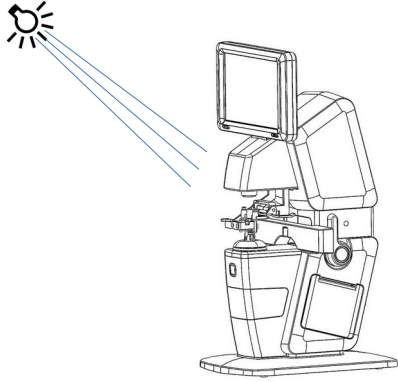

The diagram shows a line drawing of a medical device, possibly a microscope or similar diagnostic tool, with a large screen at the top. To the left of the device is a sun icon with rays. Three blue lines represent light rays originating from the sun icon and pointing towards the screen of the device, illustrating the warning against bright light exposure.

# Label

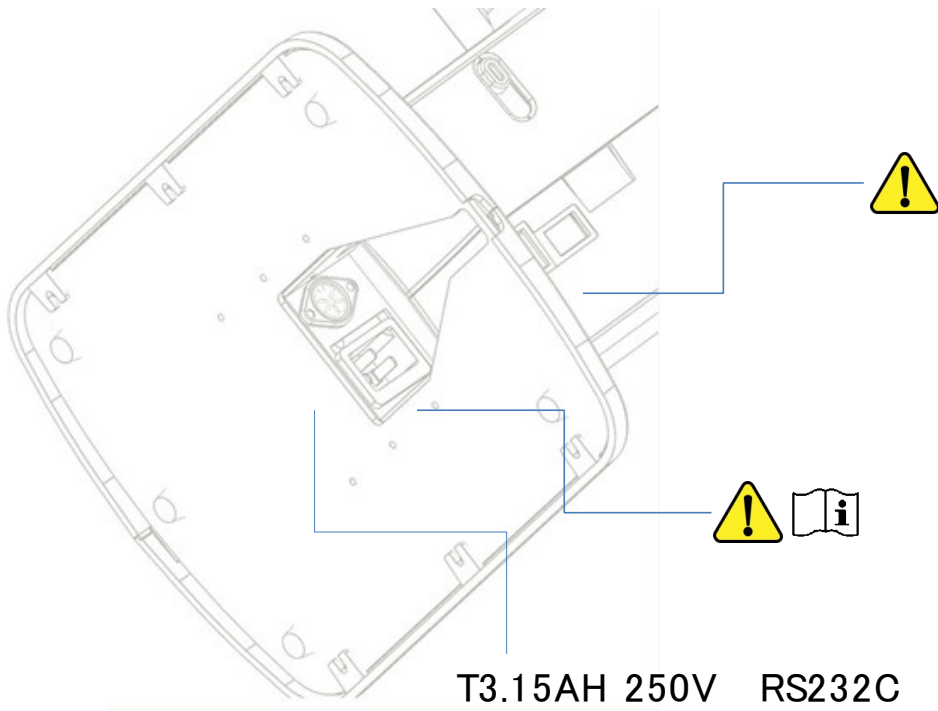
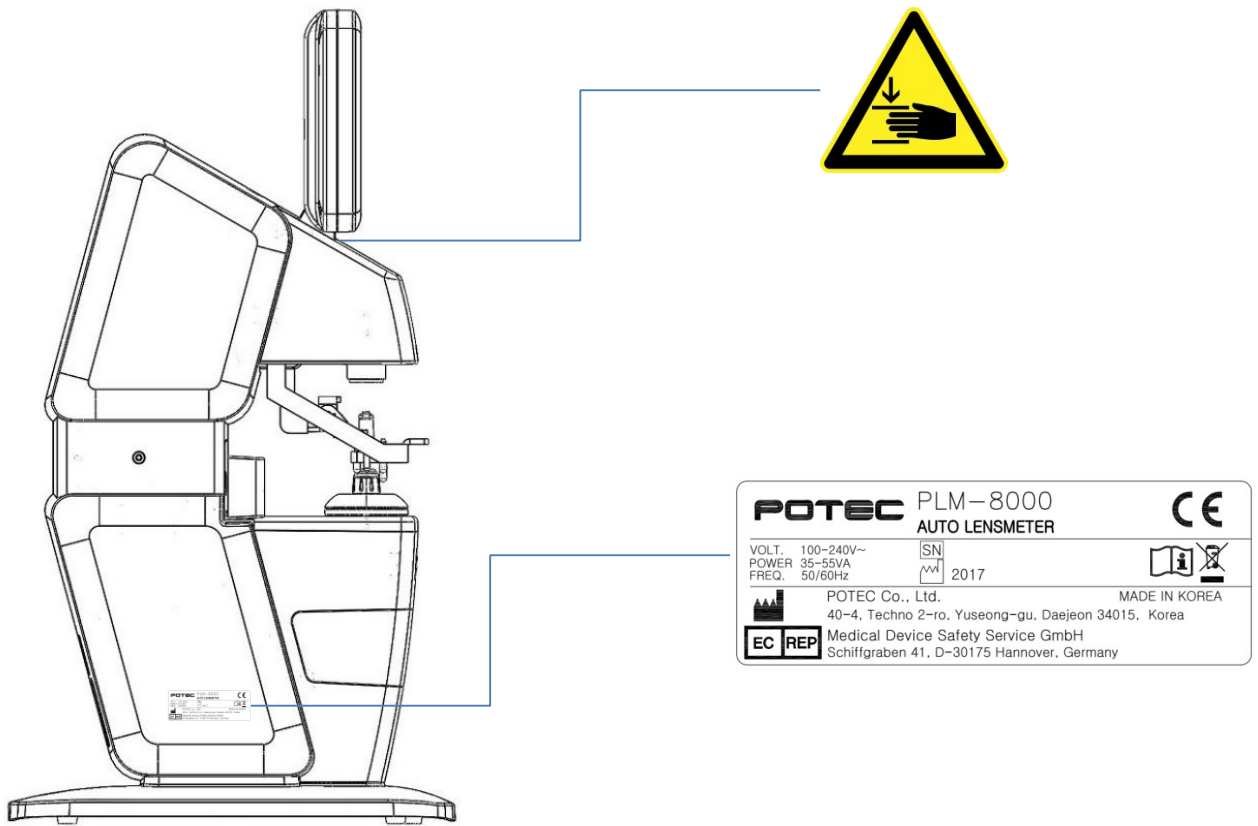



# CONTENTS

IMPORTANT NOTICE .....	I
SAFETY INFORMATION .....	II
For EU Countries.....	II
Symbols marked on the Instrument.....	II
General Safety Information.....	III
Label.....	VII
1. Introduction .....	3
1.1 General description .....	3
1.2 Classifications .....	3
2. Features .....	4
3. Notes for Using the Instrument.....	5
4. Description .....	6
4.1 Configuration .....	6
4.2 Accessories .....	7
4.3 Installation and Preparation .....	8
4.3.1 Preparation before use.....	8
4.3.2 Instruction and operation sequence.....	8
4.3.3 Storage after use.....	9
4.4 Operating panel .....	10
4.4.1 Basic operation.....	10
4.4.2 Measurement display.....	10
4.4.3 UV/BLUE Display.....	12
4.4.4 PD Display.....	13
4.4.5 User Setup display.....	14
5. Measurement.....	19
5.1 Preparation .....	19
5.2 Measuring general lenses .....	19
5.3 Measuring multi-focal lenses .....	20
5.3.1 Structure of the progressive power lens.....	20
5.3.2 Measuring progressive power lenses.....	20
5.3.3 Measuring Bifocal / Trifocal Lenses.....	21
5.4 Measuring contact lenses .....	22
5.5 Measuring UV / BLUE .....	23
5.6 Measuring prismatic lenses .....	23

- 5.7 Measuring PD / OH .....23
- 5.8 Power-saving mode .....24
- 5.9 Connection with external optometry equipment .....24
- 6. Self-diagnosis and Maintenance .....25
  - 6.1 Before contacting the service personnel .....25
  - 6.2 Replacing Print paper .....26
  - 6.3 Replacing Ink cartridge .....27
  - 6.4 Cleaning the device .....28
  - 6.5 Cleaning the cover glass .....28
  - 6.6 Fuse Replacement .....28
  - 6.7 Service Information .....30
- 7. Specification .....31
  - 7.1 Specifications .....31
  - 7.2 Components .....32

# 1. Introduction

## 1.1 General description

This device aims to take the measurements of vertex powers, cylinder axis, prismatic power and prism base setting within a restricted area of unprocessed lens, processed framed lens and contact lens, Auto Lensmeter PLM-8000 also has functions to measure UV/BLE transmission.

As an external feature, the angle of the LCD can be changed. User is able to measure the PD and OH value with the horizontal and vertical ruler GUI after adjusting the extended LCD at the lowest angle.

## 1.2 Classifications

Classification of equipment: Class I / Rule 12 (MDD, Annex IX)

Protection against electric shock: Class I;

Applied part of equipment: No applied part (ok);

Protection against harmful ingress of water: Ordinary (IPX0) (ok);

Method of sterilization: Not applicable (ok);

Stability of use in an Oxygen Rich Environment: Not suitable (ok);

Mode of operation: Continuous operation (ok)

## 2. Features

- (1) Measuring various lenses  
This auto lensmeter can measure single vision lenses, bifocals (trifocals) lenses, progressive power lenses, and contact lenses.
- (2) Wide measurement range of refractive powers  
The PLM-8000 has a wide measurement range of refractive powers from -25D to +25D, which even enables the measurement of lens for the severely nearsighted.
- (3) Measurement of UV and Blue transmission of a lens.
- (4) Easily connectable to other devices  
This lensmeter is designed in such a way that the lensmeter can be easily connected to other devices (PC, PRK-Series, PDR-7000).
- (5) Built-in the printer  
The PLM-8000 has built-in printer so it is possible to print the measurement data easily.
- (6) User is able to measure the height of the optical center with glasses PD and frame information.

### 3. Notes for Using the Instrument

- (1) Do not strike or drop the instrument. Strong impact causes the instrument to be damaged and malfunction. Handle the instrument carefully.
- (2) Do not expose the instrument directly to sunlight or bright indoor lighting, as this may affect the precise measurement of the instrument.
- (3) When other devices are to be connected to the instrument, follow the guidance of the suppliers of the devices.
- (4) Be sure to keep the cover glass clean. If the cover glass is contaminated with dust or foreign matter, the instrument may malfunction or perform inaccurate measurement.
- (5) If you encounter any abnormal condition, such as smoke, smell, or noise, when in use, pull out the power cord immediately, and then follow the guidance of the supplier.
- (6) Never use an organic solvent, such as alcohol, thinner, benzene, etc., to wipe the exterior. It may ruin the surface of the instrument.
- (7) When the PLM-8000 is to be moved, be sure to confirm that the power switch is turned OFF. Then, move the instrument while holding the lower part of the main body with both hands.
- (8) When the PLM-8000 is not used at the long time, please turn off the power and put the dust cover.

(9) Environment conditions.

In use	Temperature : +10°C ~ +40°C Humidity : 30% ~ 90% RH Pressure : 80 ~ 106 kPa
In storage (non packaging)	Temperature : -10°C ~ +55°C Humidity : 10% ~ 95% RH Pressure : 70 ~ 106 kPa
In transport & storage (packing)	Temperature : -40°C ~ +70°C Humidity : 10% ~ 95% RH Pressure : 50 ~ 106 kPa

NOTE	“In storage(non packaging)” state is as follows; Specimen unprotected, ready for operation, power supply not connected
------	---------------------------------------------------------------------------------------------------------------------------

# 4. Description

## 4.1 Configuration

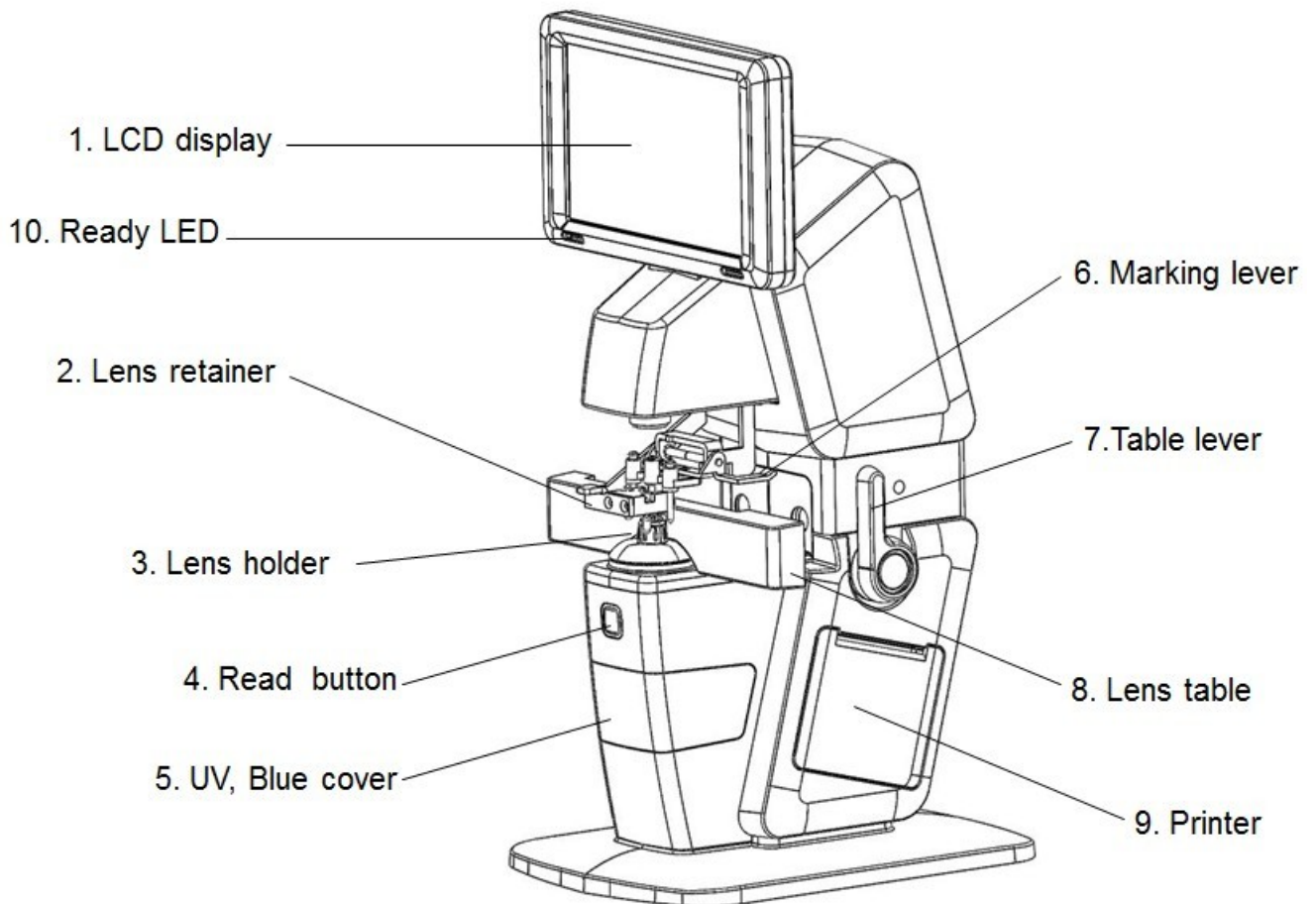

Name	Function
1. LCD Display	7.0 inch TFT Color LCD Monitor, Touch
2. Lens retainer	To fix the lens
3. Lens holder	Measure the lens when the lens is fixed on the lens holder. This is the basis for measurements When measuring contact lenses, replace them with the supplied contact lens holder
4. Read button	To read measured data
5. UV, Blue cover	For UV / Blue transmittance measurements
6. Marking lever	Mark a lens by pushing the lever down
7. Table lever	Move the lens table forward and backward
8. Lens table	Touched the eye glasses frame
9. Printer	Printing the measurement data
10. Ready LED	The LED is illuminated in the direction of the lens being measured When measuring a single lens, all LEDs are off. When in the power save mode, it blinks every 5 seconds.

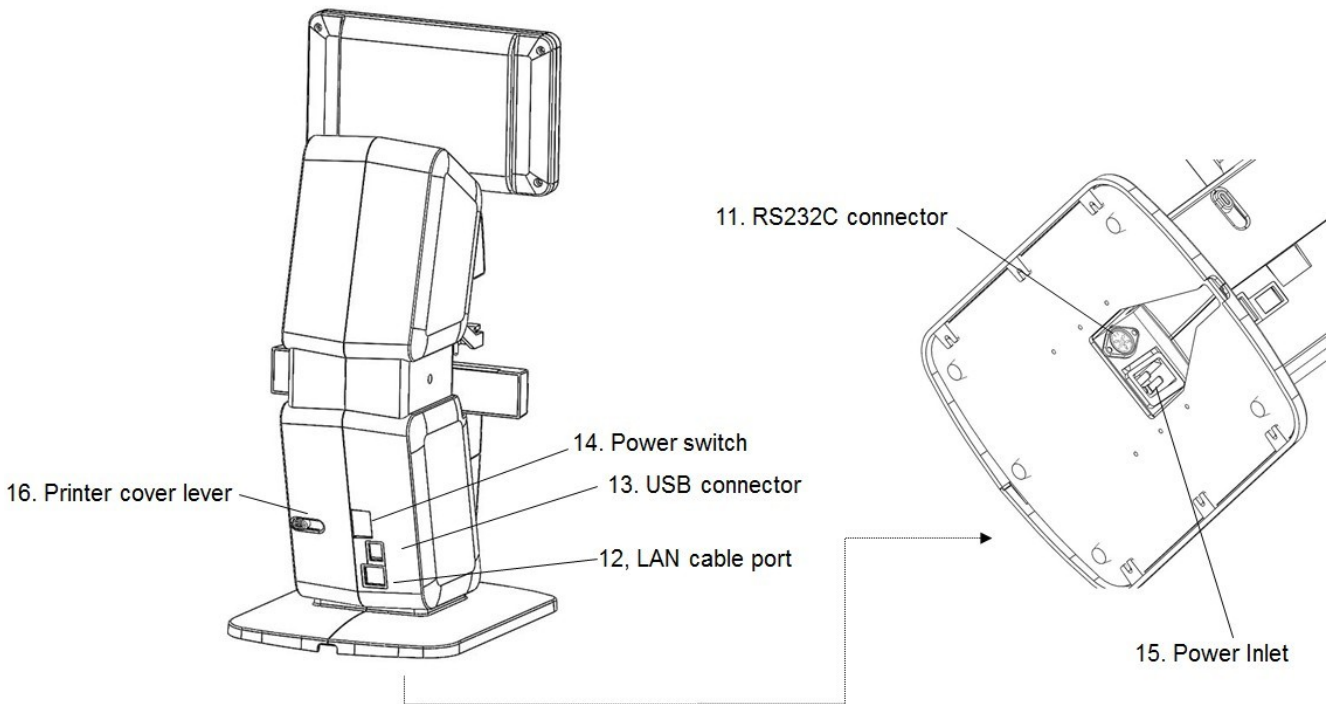

Name	Function
11. RS232C connector	To connect communication with other equipment(PC, PRK-Series, PDR-7000)
12. LAN cable port	-
13. USB connector	To upgrade S/W, Not for everyday use
14. Power switch	Turn on or off power the device
15. Power Inlet	Connect a power cord
16. Printer cover lever	To open the printer cover at the time of replacing the printer paper

 <b>CAUTION</b>	If you want to connect the input / output signal ports and other devices that must meet IEC standards (IEC60950 IT equipment, IEC60601 medical equipment) If in doubt should contact POTECH or your authorized distributor.
----------------------------------------------------------------------------------------------------	--------------------------------------------------------------------------------------------------------------------------------------------------------------------------------------------------------------------------------

## 4.2 Accessories

- (1) Operation manual
- (2) Contact lens support
- (3) Dust cover
- (4) Power cable

## 4.3 Installation and Preparation

### 4.3.1 Preparation before use

- (1) Open the box.
- (2) Make sure all articles are there (printing paper, dust cover, Operator's Manual etc.).
- (3) Set the device on the table.

NOTE	Don't install the machine under bright light or avoid surrounding bright light and direct sun light for better result.
NOTE	Move the device with both hands at the lower part of the main body

- (4) Remove protection tapes on lens holder, marking lever, table lever and UV, Blue cover.
- (5) Remove dusts, especially on the cover glass.

### 4.3.2 Instruction and operation sequence

- (1) Connect the power cord on the bottom parts of device to provide power.

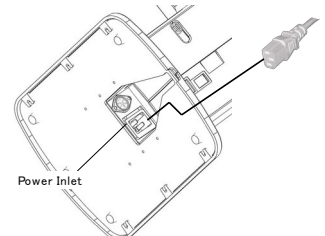

WARNING	Only operate the instrument with the power supply indicated on the rating plate. Otherwise, it may result in fire or electric shock.
WARNING	Be sure to turn OFF the power switch before connecting or disconnecting the cables. Also, do not handle them with wet hands. Otherwise, you may get an electric shock that may result in death or serious injury.

- (2) Turn the power switch on.

Make sure the device operates properly after turning on the power switch.

While the device is starting up, do not place the lens on the lens holder.

The initial screen is displayed on the LCD monitor and the device is initialized.

Wait until the measurement screen is displayed.

If a problem occurs during start up, screen will display the error message

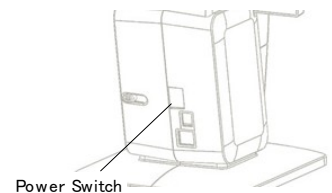

NOTE	Do not turn off the device before finishing initialization.
------	-------------------------------------------------------------

- (3) Confirm that the measurement screen is displayed
- (4) If the brightness of the screen is too bright or too dark, change it in User Setup mode.
- (5) Touch buttons what you want.  
Refer to operation manual.



### 4.3.3 Storage after use

- (1) When the PLM-8000 is not used for a long time, please turn off the power and disconnect the power cord from the power outlet.
- (2) Clean with soft cloth.
- (3) Clean the cover glass's dusts by wind blower and soft cloth.
- (4) Put the dust cover.
- (5) Do store at the following place
  - A non-humid place
  - A flat place
  - Where vibration or shock is not applied
  - Not in the vicinity of other flammables vapors or liquids
  - Not in the vicinity of direct sunlight
- (6) Store the accessories and cords for next operation

NOTE	In storage    Temperature : -10°C ~ +55°C Humidity        : 10% ~ 95% RH Pressure        : 70 ~ 106 kPa
------	---------------------------------------------------------------------------------------------------------------

## 4.4 Operating panel

### 4.4.1 Basic operation

Basic operation of the PLM-8000 is performed on the touch panel.

### 4.4.2 Measurement display

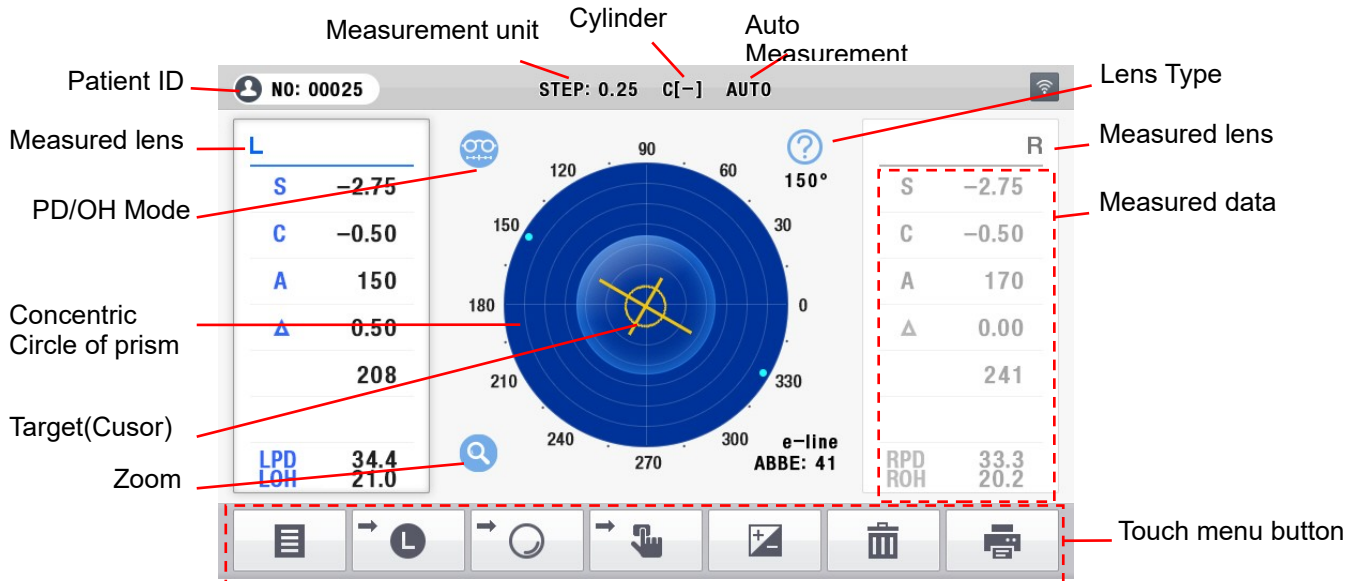

#### (1) Measured data

Indicates the following data:

- S : Spherical value
- C : Cylinder value
- A : Angle of cylinder shaft
- P : Prism value
- ADD : Progressive ADD value
- RPD, LPD : PD value

#### (2) Concentric circle of prism

Concentric circles indicates 1 Prism~7Prism respectively.

#### (3) Measured lens

Indicates whether the lens being measured is a monacle or a right-side/left-side lens.

#### (4) Cylinder mark

Cylinder mark is indicated as '+', '-' according to 'CYLINDER' of user menu.

#### (5) Measurement step

Display step of 0.01, 0.06, 0.12, or 0.25.

(6) Auto Measurement

Display whether the measurement is used automatically or manually.

(7) Lens Type

Indicates the type of the lens which is presently being measured.

(8) Progressive guide line

It indicates the location to find near & distance power.

☞ Progressive guide line is displayed only when progressive lenses are measured.

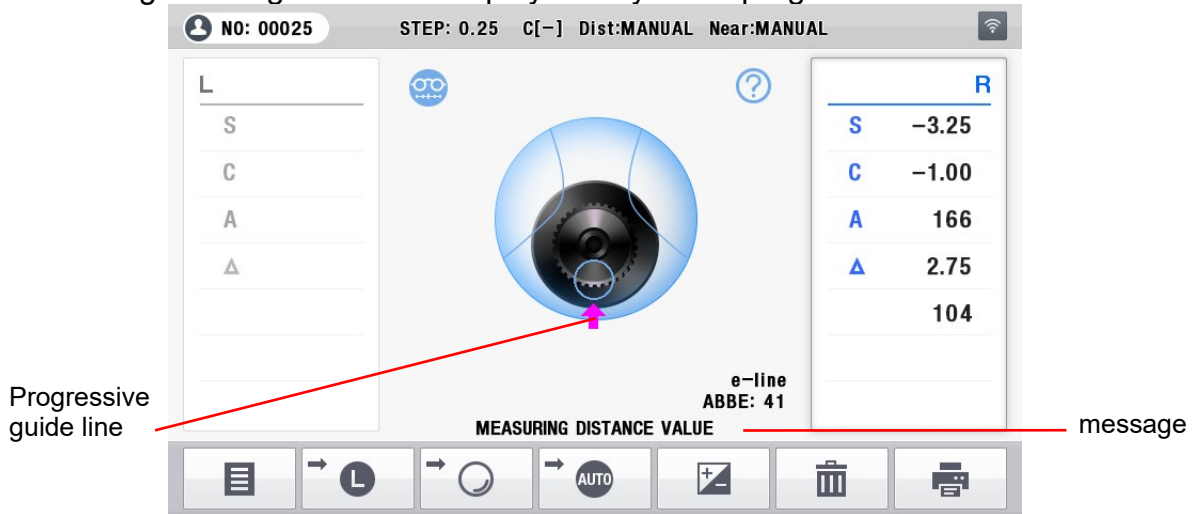

(9) Target

Indicates the optical center of the lens being measured.

(10) Touch button

	Button for selecting a user setup mode
	In case of single lens, you can switch between left and right selection of the framed lens or you can select left/right lens
	Changes the screen to the normal measurement screen.
	Changes the screen to the progressive measurement screen.
	To enter the UV/Blue measurement screen
	Changes the screen to the normal measurement screen in auto measurement.
	Press this button in order to automatic measurement
	Press this button in order to start manual measurement

	Press this button in order to change CYL (-) from.
	Press this button in order to change CYL (+) from.
	Button for clearing the value of the measured data to '0'
	Button for print out the measured value
	To enter the UV or Blue measurement icon screen
	To enter the UV/Blue measurement graph screen
	Adjust the current transmission to 100%(UV and BLUE)

### 4.4.3 UV/BLUE Display

2. Current Transmission Ratio

1. Measured data

3. Current Protection Ratio

L		R	
λ/nm		λ/nm	
UV	0%	UV	0%
BLUE	15%	BLUE	16%
PROTECT		PROTECT	
UV	100%	UV	100%
BLUE	85%	BLUE	84%

UV PROTECT 99%

UV BLUE

100%

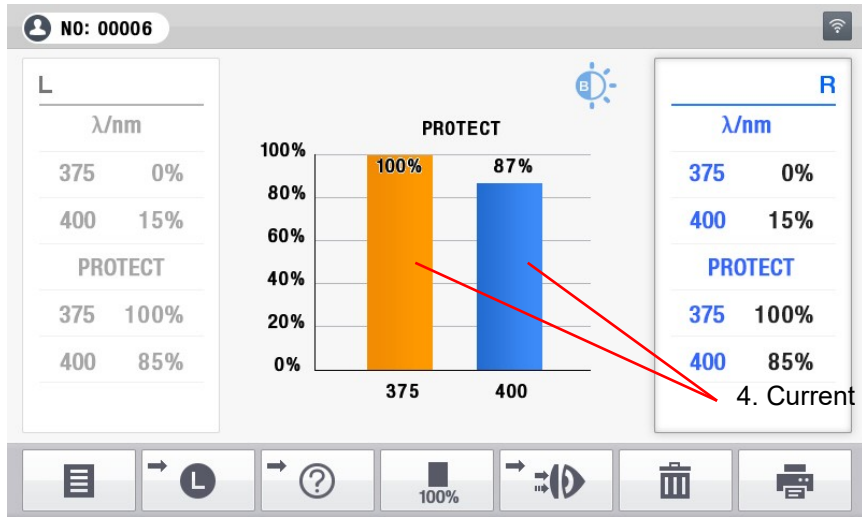

4. Current Protection Height

(1) Measured data

Indicates the following data:

- UV : UV transmission value.
- BLUE : BLUE transmission value.
- Protect UV : UV protect value.
- Protect BLUE : BLUE protect value.

(2) Current Transmission Ratio

Display the transmission ratio in a bar graph form.

(3) Current Protection Ratio

UV PROTECT: Display the UV protection ration

BLUE PROTECT: Display the BLUE protection ration

(4) Current Protection Height

Show the height of the current protection.

### 4.4.4 PD Display

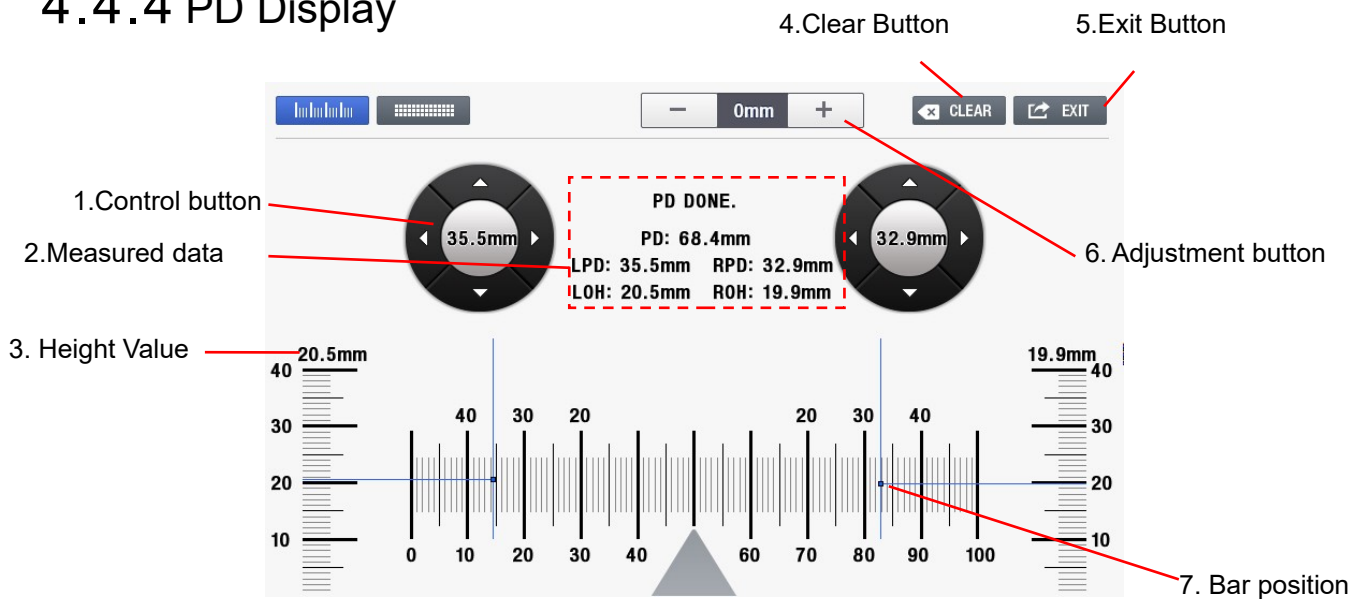

(1) Control button

Four-way arrow buttons adjust the bar position

(2) Measured data : RPD, LPD, ROH, LOH

(3) Height Value

(4) Clear Button

(5) Exit Button

(6) Adjustment button : Glasses frame thickness adjustment button

(7) Bar position

## 4.4.5 User Setup display

User mode is provided as Touch Screen for users to set-up directly.

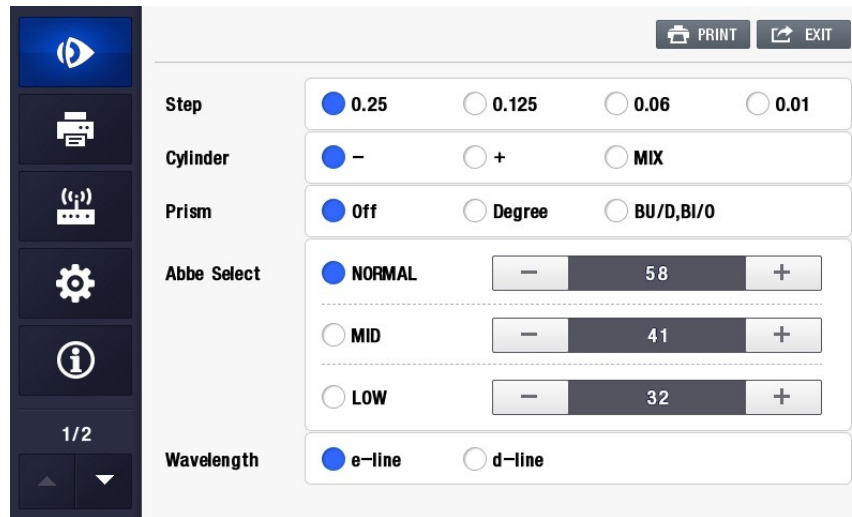

### (1) STEP

- 1 0.25 : Display step, 0.25 step
- 2 0.125 : Display step, 0.125 step
- 3 0.06 : Display step, 0.06 step
- 4 0.01 : Display step, 0.01 step

### (2) CYLINDER

- 1 - : The cylinder reading direction to “-”.
- 2 + : The cylinder reading direction to “+”.
- 3 MIX : The cylinder reading direction to “+” or “-”.

### (3) PRISM

- 1 OFF : No prism display.
- 2 DEGREE : Polar coordinates.
- 3 BU/D, BI/O: Rectangular coordinates.

### (4) Abbe Select (This can be applied to the high-refractive lens.)

- 1 NORMAL : Designated value for NORMAL ABBE(= 50 ~ 60)
- 2 MID : Designated value for MID ABBE(=40~49)
- 3 LOW : Designated value for LOW ABBE(=30~39)

### (5) Wavelength

- 1 e-line : Display the refractive power according to e-line
- 2 d-line : Display the refractive power according to d-line

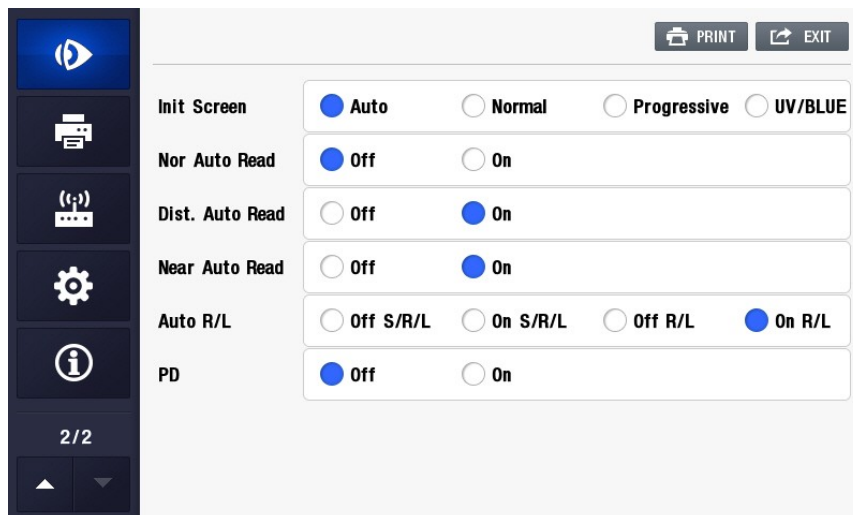

(6) Init Screen

1 Auto

When the lens on the lens holder is detected as a progressive addition lens, the normal measurement screen changes to the PAL measurement screen automatically.

- When the distance portion of a PAL is placed on the lens holder, it is not detected as a PAL

- In such a case, put the intermediate portion (progressive zone) or near portion area on the lens holder

- 2 Normal : Normal lenses mode
- 3 Prog : Prograssive lenses mode
- 4 UV/BLUE : UV / BLUE lenses mode

(7) Nor Auto Read

- 1 OFF: Enable automatic measurement.
- 2 ON : Disable automatic measurement.

☞ Only Using Normal lenses mode.

(8) Far Auto Read

- 1 OFF: Disabling the auto read function for the far portion in measurement of progressive lenses.
- 2 ON : Enabling the auto read function for the far portion in measurement of progressive lenses.

(9) Near Auto Read

- 1 OFF: Disabling the auto read function for the near portion in measurement of progressive lenses.
- 2 ON : Enabling the auto read function for the near portion in measurement of progressive lenses.

(10) AUTO R/L

- 1 OFF S/R/L : Disable automatic transfer function in case of left/right lens



- measurement. Initial screen stands by for single lens measurement.
- 2 ON S/R/L : Enable automatic transfer function in case left/right lens measurement. Initial screen stands by for single lens measurement.
- 3 OFF R/L : Disable automatic transfer function in case of left/right lens measurement. Initial screen stands by for right lens measurement.
- 4 ON R/L : Enable automatic transfer function in case left/right lens measurement. Initial screen stands by for right lens measurement.

(11) PD

- 1 OFF: Disable PD function.
- 2 ON : Enable PD function.



(12) PRINTER

- 1 OFF: Not used.
- 2 ON : Print out in the unit of 24 column by means of the internal printer.

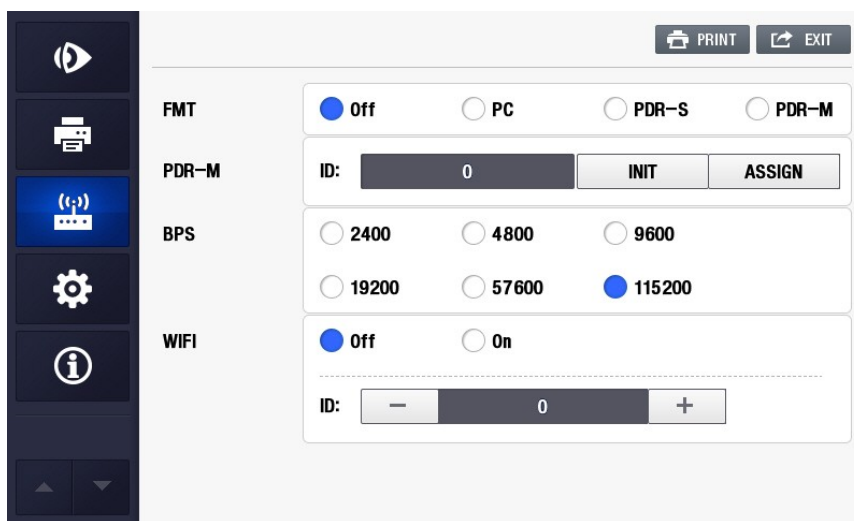

(13) FMT

- 1 OFF: Turn off the external communication.
- 2 PC : Turn on the external communication.

- 3 PDR -S: Turn on the protocol between single PDR-7000.
- 4 PDR -M: Turn on the protocol between multi PDR-7000.

(14)PDR-M : Setting the multi PDR-7000

(15)BPS

Select the speed of the external communication

- 1 2400 : communication speed by 2400.
- 2 4800 : communication speed by 4800.
- 3 9600 : communication speed by 9600.
- 4 19200 : communication speed by 19200.
- 5 57600 : communication speed by 57600.
- 6 115200 : communication speed by 115200.

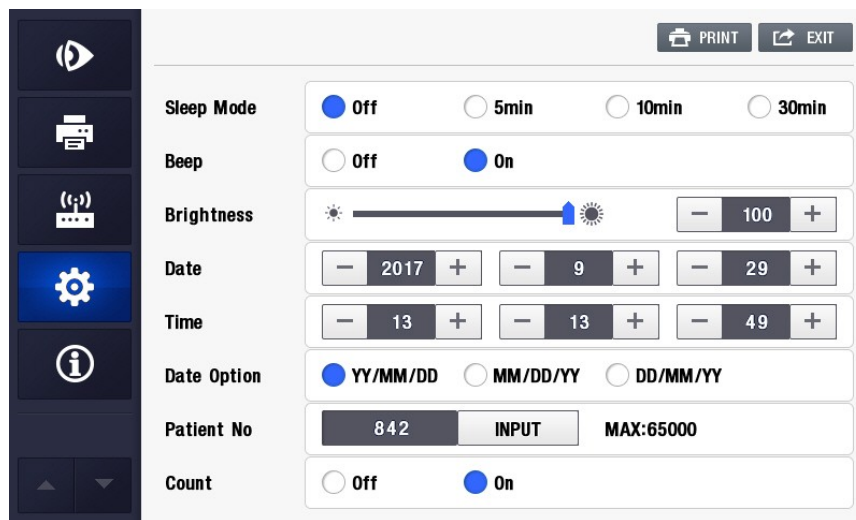

(16)Sleep Mode

- 1 OFF : Disable Power Save Function.
- 2 5Min : Enter Power Save Mode if there is no operation by operator for 5 minutes.
- 3 10Min : Enter Power Save Mode if there is no operation by operator for 10 minutes.
- 4 30Min : Enter Power Save Mode if there is no operation by operator for 30 minutes.

(17)BEEP

- 1 ON : Enable Sound.
- 2 OFF : Disable Sound.

(18)Brightness

Adjust the brightness of LCD.

Pressing '+' or '-' button to adjust the brightness of LCD

(19)Date

Pressing '-' or '+' button renders the related item to be decreased or increased by "1".

2001 ~ 2099 : Year

01 ~ 12 : Month

01 ~ 31 : Day

(20) TIME

Pressing '-' or '+' button renders the related item to be decreased or increased by "1".

00 ~ 23 : Hour

00 ~ 59 : Minute

00 ~ 59 : Second

(21) Date Option

Order of displaying the date

(22) Patient No

Setting of the patient number

(23) Count

To select whether using the patient number or not.

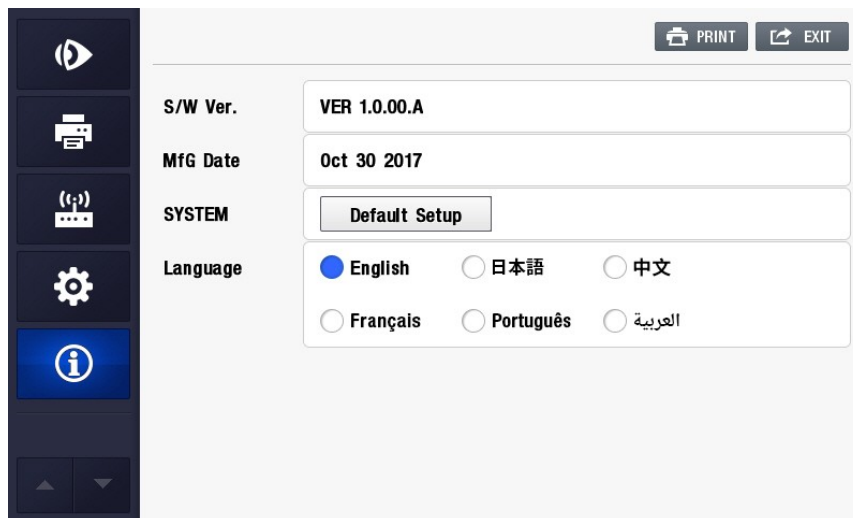

(24) S/W Ver. / MfG Date

It displays the version of the Software that is currently installed in the product.

(25) System

If you press the "Default Setup" button, the system variable will be initialized.

(26) Language

Setting of the Language

# 5. Measurement

## 5.1 Preparation

- (1) Connect the power cable.
- (2) Turn ON the power.
  - ☞ Do not turn on the power as the lens is on the lens table or else it is possible to occur errors as measuring or starting. If 'Error-Initial Error!!!' or 'Setup Data Error', 'UV Init Error', 'BLUE Init Error' is seen to the screen, refer the '6. Self-diagnosis and Maintenance'.

<p> <b>WARNING</b></p>	<p>If any of the following occur, immediately turn OFF the power switch, unplug the power cable from the AC outlet, and contact the dealer or the agent who/where you purchase this machine.</p> <ul style="list-style-type: none"> <li>● When there is smoke, strange odor or abnormal sound.</li> <li>● When liquid has been spilled into the instrument or a metal object has entered through an opening.</li> <li>● When the product has been dropped or its housing damaged</li> </ul>
---------------------------------------------------------------------------------------------------------	---------------------------------------------------------------------------------------------------------------------------------------------------------------------------------------------------------------------------------------------------------------------------------------------------------------------------------------------------------------------------------------------------------------------------------------------------------------------------------------------

## 5.2 Measuring general lenses

- (1) Connect the power cable.
- (2) Turn ON the power.
- (3) Place the lenses on the nosepiece.
  - 1 Press the LR touch button(  ) to specify the left-eye lens or the right-eye lens as necessary.
  - 2 Place the lens on the nosepiece with the convex side up.
- (4) Lower the lens retainer.

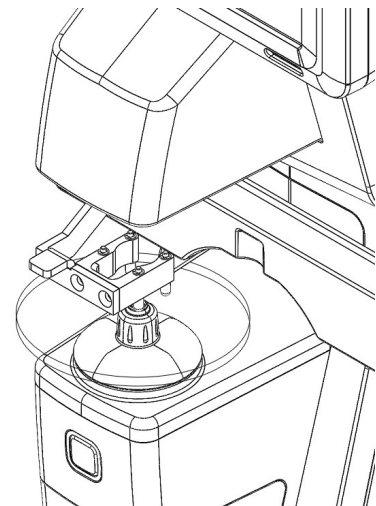

- (5) Adjust the focus.
- (6) Press the read button to store the measured value.
- (7) Raise the lens retainer, and place the other lens on the nosepiece.
- (8) Adjust the focus.
- (9) Press the read button to store the measured value. Press the Print button() to print out the measured value.

## 5.3 Measuring multi-focal lenses

### 5.3.1 Structure of the progressive power lens

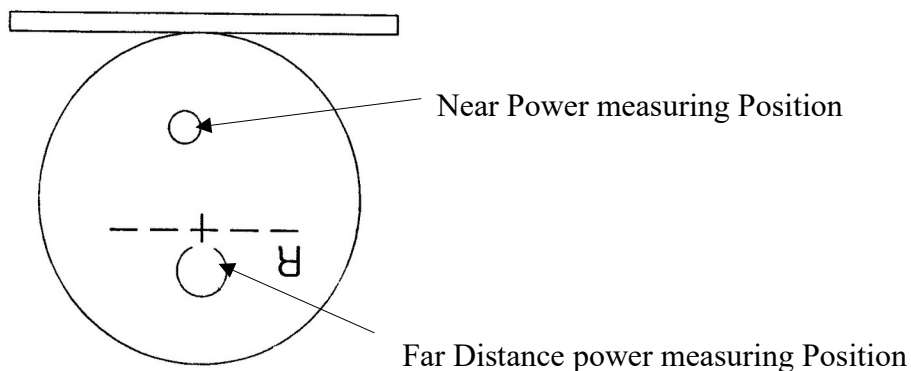

### 5.3.2 Measuring progressive power lenses

\* Basic setup mode : Dist. Auto Read – “Off” and Near Auto Read – “Off”

\* How to setup Dist Auto Read On/Off and Near Auto Read On/Off : Refer to “4.4.5 User setup display” on page 15.

- (1) Connect with power cable.
- (2) Turn on the power supply
- (3) Switch to progressive mode from user setting screen mode(Press progressive button on the normal measurement screen)
- (4) Arrange lens.

- 1 Press the LR touch button( ) to specify the left-eye lens or the right-eye lens as necessary.

- 2 Place the lens on the nosepiece with the convex side up.

- (5) Find far distance portion of lens as in the picture shown beside.

- 1 Move lens up/down/left/right for the indicated lens in far distance portion to be adjusted to the center of cross.
- 2 If lens is on the indicated place, beep sound is heard and measurement works.
- 3 If far distance portion is discovered,  mark is shown

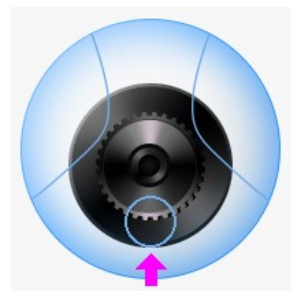

temporarily.

☞ In case of the far distance portion is not properly discovered, press read button when far distance portion power is small regardless of cursor location.

- (6) If the far distance portion is discovered, indication of lens cursor will show to find the location of near portion and ADD value is presented on screen.

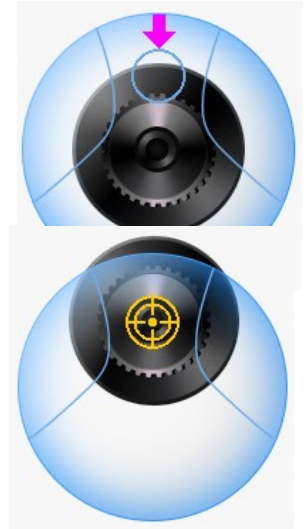

- (7) Save measured value by pressing read button. If exterior printer is supported.

☞ In case of bottom frame of near distance portion is cut out, adjacent or lens area is connected after the center of near distance portion, maintain lens table and confirm the power by pressing read button when the power is at the maximum.

☞ When measuring the left lens, the lens moves to the right about 2 ~ 3mm or When measuring the left lens, the lens moves to the right about 2 ~ 3mm the more accurate measurement can be measured.

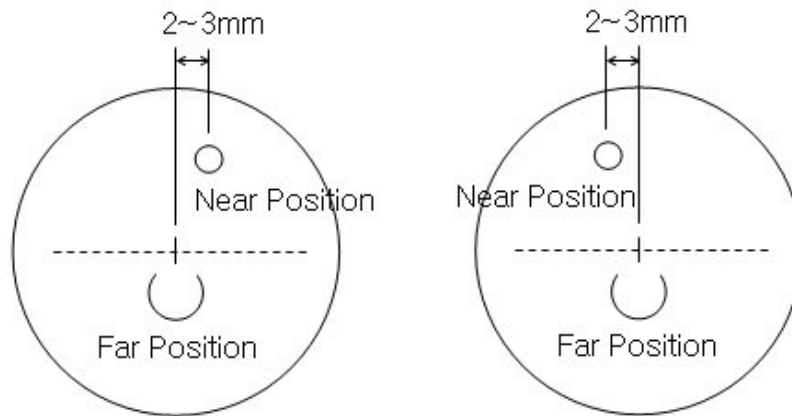

Left Lens

Right Lens

### 5.3.3 Measuring Bifocal / Trifocal Lenses

- (1) Connect the power cable.
- (2) Turn ON the power.
- (3) Switch to progressive mode from user setting screen mode(Press progressive button on the normal measurement screen)
- (4) Place the lenses on the nosepiece.

- 1 Press the LR touch button(  ) to specify the left-eye lens or the right-eye lens as necessary.
- 2 Place the lens on the nosepiece with the convex side up

- (5) Find the Far distance portion of the lens as shown in the following figure. Mostly the optical center of lenses is the Far distance portion of the lenses.  
 (Bifocal Lens: Distance portion → Near portion)  
 (Trifocal Lens: Distance portion → Intermediate portion → Near portion)

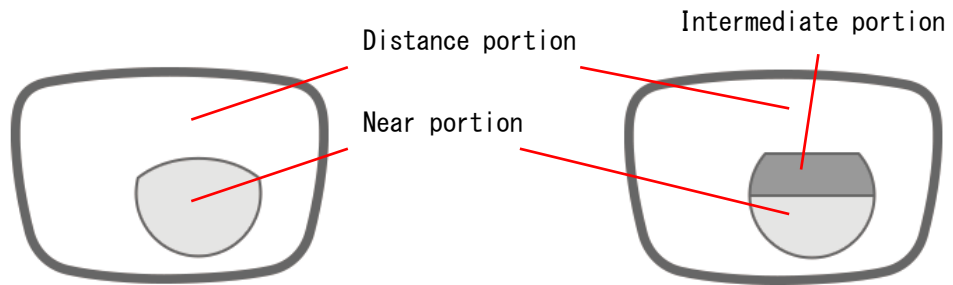

- (6) After finding the Far distance portion of the lens, pull down the lens then ADD value will show up if the near distance portion of the lens is found.

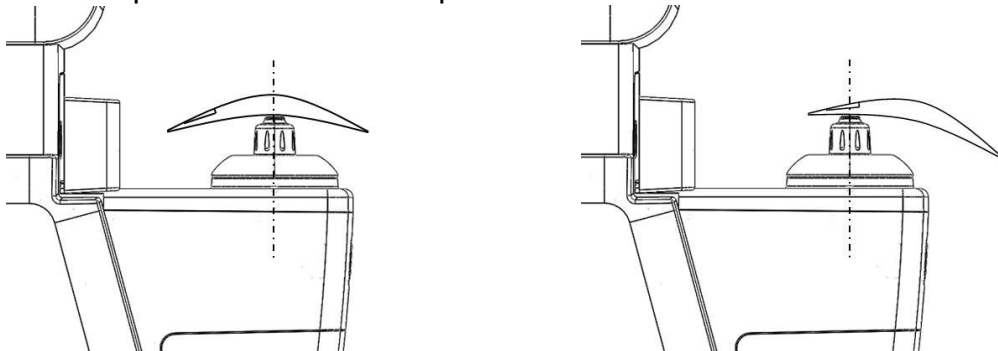

- (7) Press the read button to store the measured value. Press the Print button to print out the measured value.

## 5.4 Measuring contact lenses

- (1) Connect the power cable.
- (2) Turn ON the power.
- (3) Replace the nosepiece with the nosepiece for contact lens.
- (4) Place the lenses on the nosepiece.
  - 1 Press the LR touch button to specify the left-eye lens or the right-eye lens as necessary.
  - 2 Place the lens on the nosepiece with the convex side up.

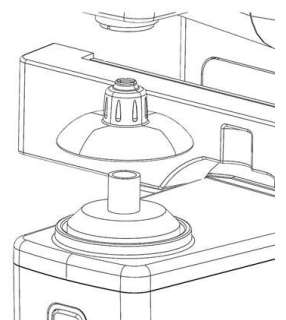

- (5) Adjust the focus.
- (6) Press the read button to store the measured value.
- (7) Press the Print button to print out the measured value.

## 5.5 Measuring UV / BLUE

- (1) Connect the power cable.
- (2) Turn ON the power.
- (3) Take out UV, BLUE cover and put in the lens of glasses like the below picture



- (4) Press the read button to store the measure value.  
When measuring UV, BLUE at the same time, click the graph button then the bar graph is seen on the screen

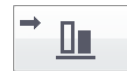

## 5.6 Measuring prismatic lenses

- (1) Connect the power cable.
- (2) Turn ON the power.
- (3) Place the lenses on the nosepiece.
  - 1 Press the LR touch button to specify the left-eye lens or the right-eye lens as necessary.
  - 2 Place the lens on the nosepiece with the convex side up.
- (4) Lower the lens retainer.
- (5) Change the prism indication type on the basis of the prism type (X-Y(BU/D,BI/O), P-B(polar coordinates: angle) indicated on the prescription.
- (6) Adjust the focus.
- (7) Press the read button to store the measure value.
- (8) Mark using the marking lever.
- (9) Raise the lens retainer, and place the other lens on the nosepiece.
- (10) Adjust the focus.
- (11) Press the read button to store the measured value. Press the Print button to print out the measured value.

## 5.7 Measuring PD / OH

- (1) Connect the power cable.

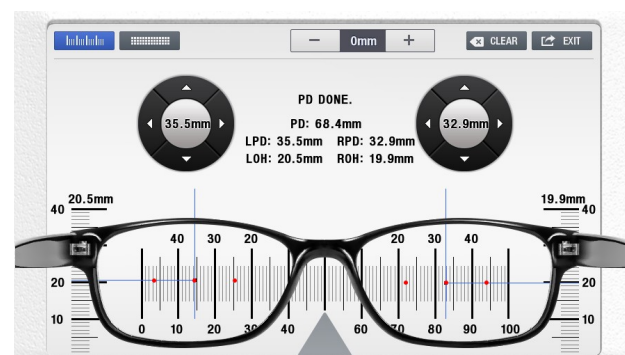



- (2) Turn ON the power.
- (3) Pull down the LCD as much as possible
- (4) Click the glasses shaped icon 
- (5) Put the marked lens on the LCD
- (6) Adjust it with the +, - icon in the light of a thickness of a glass frame
- (7) Align the horizontal and vertical bar with the both sides abstract point by using the direction indicator button
- (8) Press the read button to store the measure value.
- (9) Press the EXIT button
- (10) Press the Print button to print out the measured value

## 5.8 Power-saving mode

The power-saving mode is activated if no operation (Not operated read button and touch) or no measure is carried out for approximately 5 minutes, 10 minutes, 30 minutes in the measurement mode. In the power-saving mode, the READY lamp flickers. If pushing the Read button or touch, it is returned to the measurement mode in the power-saving mode.



## 5.9 Connection with external optometry equipment

Using an external connection socket, can be connected with external optometry equipment. The external optometry equipment of the POTEK are connected by connector cable which be provided from POTEK.

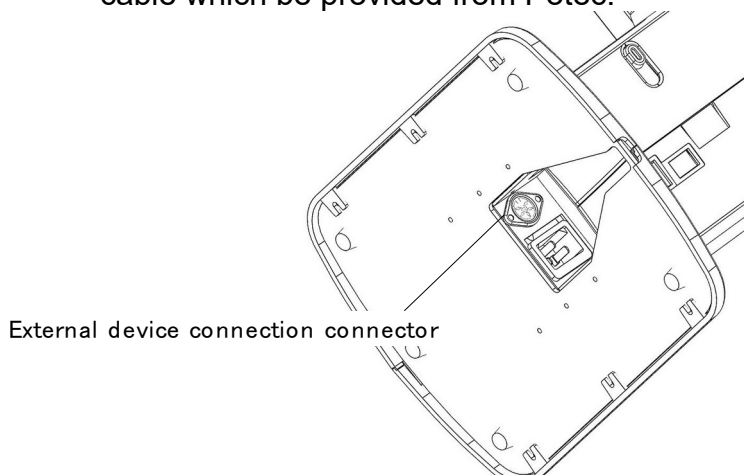
- (1) Connect on the printer socket of the left side on the real bottom to a 6-pin connector cable which be provided from Potec.



- (2) Connector cable to connect to the external device.
- (3) Measured the Lens.
- (4) Click the printer button in the menu.

 CAUTION	When user connected external optometric equipment , determine the pin number of connectors.
 NOTE	Recommended Products : Optometry equipment of POTEC (PRK-7000, PRK-8000, PDR-7000).
 NOTE	USB port to upgrade the system's specifications for the terminal. Service personnel will be used.

6.

# 7. Self-diagnosis and Maintenance

## 7.1 Before contacting the service personnel

When the instrument operates abnormally or malfunctions, a warning message will appear on the display.

In this case, take the following measures.

When the instrument does not work properly even after the following measures are taken, turn OFF the instrument, and contact an authorized supplier.

(1) Message when the power is turned on

Message	Cause	Measure
ERROR – Initial Error !!!	Product initialization error	Please check on the Lens holder
Setup Data Error UV Setup Error BLUE Setup Error	Trouble of Data in Product	Contact an authorized supplier
UV Init Error BLUE Init Error	Product initialization error	Check whether something is on the UV, BLUE sensor or not

(2) Message during measurement

Message	Cause	Measure
ERROR	Optical problems	Please check on the Lens holder
PDR-7000 Com Error!!	Communication cable issue	Check the connecting status of the communication cable
Out of Range !!!	The lens is out of the physical measurement range	Place the lens on the center of the lens support
GUI Upload Error	GUI SD card faulty	Contact an authorized supplier
SPH > +27D, SPH < -27D	Sphere value exceeds $\pm 27D$	Check the power of the lens.
CYL > +11D, CYL < -11D	Cylinder value exceeds $\pm 11D$	Check the power of the lens.
ADD > +11D	ADD value exceeds 11D	Check the power of the lens.
Prism > 21	The lens with the prism value exceeding 21 $\Delta$ is on the nosepiece.	Check the power of the lens.
PRINTER PAPER EMPTY!	The print button was pressed with no printer paper set.	Fill the printer paper.

(3) In case of abnormal measured value without mark of measured message.

It is the case of dust or alien substances under the lens holder. To handle such case, measure after reinstalling the lens holder when dust or alien substances are all removed. Please contact to sales agency if the problem continuously occurs.

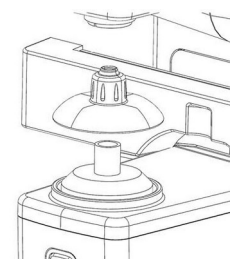

## 7.2 Replacing Print paper

When a red line appears on the side of the printer paper, it means that the paper is running short.

In such a case, stop using the printer and replace the roll with a new one.

NOTE	In the absence of printing paper do not run the printer. It may damage the printer head.
NOTE	Do not pull out printing paper forcefully. It may cause malfunction of the printer.
NOTE	According to the new paper quality, printing result may differ or paper skew may occur. Please cut approx 60~70cm length of paper to readjust when above malfunction is occurred

- (1) Slide the printer cover lever at the rear of the device to open the cover.



- (2) Take out the used printer paper.



(3) Set the new printer paper..



(4) Press the right and left sides of the printer cover to close the printer.



 <b>CAUTION</b>	Be careful not to touch the printer head inside the device.
----------------------------------------------------------------------------------------------------	-------------------------------------------------------------

## 7.3 Replacing INK PEN ASSEMBLY

(1) Remove the c-ring with tweezers.

(2) Remove the ink pen assembly.

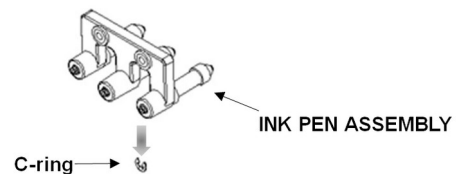

(3) Insert the spring into the holder.

(4) Insert the new Ink pen assembly into the holder.

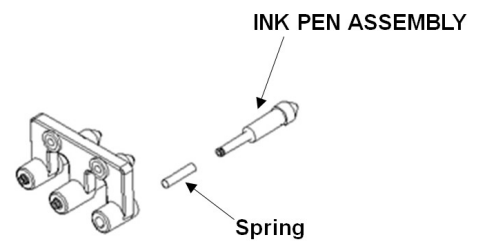

- (5) Set the c-ring again.

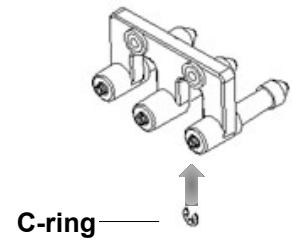

## 7.4 Cleaning the device

- (1) Basically keep the instrument clean. Do not use highly volatile materials, such as thinner, benzene, etc.
- (2) Sprinkle a little liquid soap on soft cloth, squeeze the water from the soft cloth, and clean the parts of the instrument.

## 7.5 Cleaning the cover glass

- (1) Remove the lens holder
- (2) Clean the cover glass.

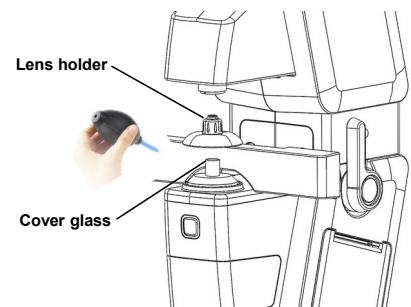

### CAUTION



Clean the cover glass under the lens holder with the [Hand Air Blower](#). The dust on the cover glass may be sharp particles. If you wipe without an air blower, the coating on the cover glass may scratch. This has the risk of affecting the measured value. Carefully remove the dust.

## 7.6 Fuse Replacement

- (1) Turn off the device
- (2) Remove the power cord
- (3) Open the fuse case  
It is easy to work with a flat screwdriver



(4) Remove the old fuse and put in the new one



(5) Close the fuse case



**CAUTION**

To avoid risk of electric shock, always disconnect the plug from the system prior to fuse replacement.

## 7.7 Service Information

### (1) Repair

If problems cannot be solved even after taking the measures indicated in section 5.1, contact a POTECH representative or distributor for repair.

Inform them of the following information, which is indicated on the nameplate of the instrument.

- Product Name : PLM-8000
- Serial Number : Seven characters indicated on the nameplate
- Problems : Detailed description is appreciated.



### (2) Product Cycle of calibration



Calibration (required to maintain the functioning of the product) of this product do not during normal performance. But, Basic lens (required necessary of product) of manufacture must do test and calibration.

### (3) Other's Information

Upon required repair of component in product, circuit diagrams, component part lists, descriptions, calibration instructions, or other information will be provided to assist service personnel to repair parts.

 <b>WARNING</b>	Arbitrary Replacement of a component by customer could result in an unacceptable risk.
----------------------------------------------------------------------------------------------------	----------------------------------------------------------------------------------------

### (4) Disposal of product

 <b>CAUTION</b>  	<p>This instrument incorporates a lithium battery, which may pollute the environment if the instrument is abandoned.</p> <p>Please ask a professional waste disposal company to handle disposal, or contact a POTECH representative or distributor before disposing of the instrument.</p>
-----------------------------------------------------------------------------------------------------------------------------------------------------------------------------------------------	--------------------------------------------------------------------------------------------------------------------------------------------------------------------------------------------------------------------------------------------------------------------------------------------



# 8. Specification

## 8.1 Specifications

### Measurement

Sphere power(SPH)	-25D ~ +25 D (0.01 / 0.06 / 0.12 / 0.25 D steps)
Cylinder power(CYL)	0D ~ ±10 D (0.01 / 0.06 / 0.12 / 0.25 D steps)
Axis(AX)	0° ~ 180° (1° step)
Addition power	0 ~ +10 D (0.01 / 0.06 / 0.12 / 0.25 D steps)
Prism power	0 ~ 20 Δ
Transmittance(UV, Blue)	0 ~ 100%

### Measurement Mode

Cylinder Mode	-, +, MIX
Prism Mode	Rectangular / Polar
Display	7.0 inch TFT COLOR LCD Monitor, Touch
Wave	e-line, d-line
Abbe value	30 ~ 60

### Others

LED wavelength	525nm, 400nm(UV), 420nm(BLUE)
Lens diameter	Max. approx. 120 mm
Marking system	Ink Cartridge type
Interface	RS-232C, USB
Printer	Thermal line printer with auto cutter

Rated Voltage	100-240V~, 50/60Hz
Power consumption	35-55VA
Size	198(W) × 245(D) × 420(H) mm
Weight	Approximately 5kg (only equipment)

### Environment conditions

In use	Temperature : +10°C ~ +40°C
--------	-----------------------------

	Humidity : 30% ~ 90% RH
	Pressure : 80 ~ 106 kPa
In storage	Temperature : -10°C ~ +55°C
(non packaging)	Humidity : 10% ~ 95% RH
	Pressure : 70 ~ 106 kPa
In transport & storage	Temperature : -40°C ~ +70°C
(packing)	Humidity : 10% ~ 95% RH
	Pressure : 50 ~ 106 kPa

## 8.2 Components

Operation manual .....	1
Contact lens support.....	1
Power cable .....	1
Dust cover .....	1