

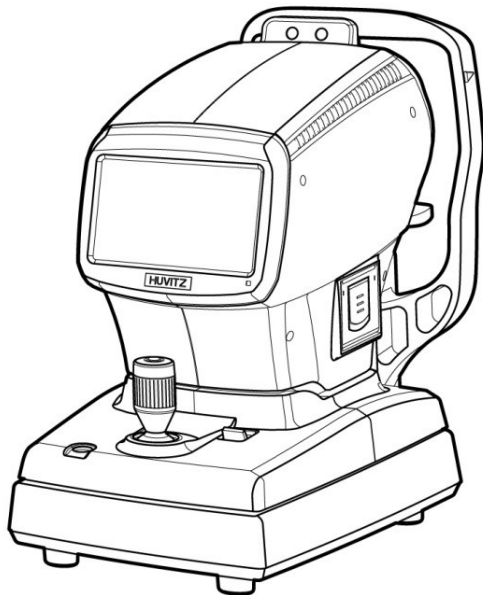

Non-Contact Tonometer

HNT-1 / 1P

User Manual





■ Important Notice

This product may malfunction due to electromagnetic waves caused by portable personal telephones, transceivers, radio-controlled toys, etc. Be sure to avoid having objects such as, which affect this product, brought near the product.

The information in this publication has been carefully checked and is believed to be entirely accurate at the time of publication. HUVITZ assumes no responsibility, however, for possible errors or omissions, or for any consequences resulting from the use of the information contained herein.

HUVITZ reserves the right to make changes in its products or product specifications at any time and without prior notice, and is not required to update this documentation to reflect such changes.



9000ENG0030-A
Ver 0.2 (2017.03.)

©2016-2017 Huvitz Co., Ltd

38, Burim-ro 170beon-gil, Dongan-gu, Anyang-si, Gyeonggi-do, 14055, Republic of Korea

All rights reserved. Under copyright laws, this manual may not be copied, in whole or in part, without the prior written consent of Huvitz Co.,Ltd.

I CONTENT

1. INTRODUCTION	5
1.1. INTENDED USE	5
1.2. OVERVIEW	5
1.3. CLASSIFICATION	5
2. SAFETY INFORMATION	6
2.1. OVERVIEW	6
2.2. SYMBOL EXPLANATION	7
2.3. ENVIRONMENTAL CONSIDERATIONS	9
2.4. SAFETY PRECAUTION	11
3. CHARACTERISTICS	15
4. NOTE FOR USE	16
5. NAMES AND FUNCTIONS OF EACH PART	18
5.1. MAIN PARTS	18
5.2. EXPLANATION OF MAIN SCREEN	21
5.2.1. Main Screen of HNT-1	21
5.2.2. Main Screen of HNT-1P	27
6. INSTALLATION OF EQUIPMENT & PREPARATION OF MEASUREMENT	30
7. BASIC OPERATIONS	32
7.1. MEASUREMENT	33
7.2. MANUAL MEASUREMENT MODE	35
7.3. AUTO MEASUREMENT MODE	42



8. OTHER MODES	47
8.1. SETUP MODE.....	47
8.2. RESULT MODE.....	61
8.3. PACHY IMAGE MODE (ONLY IN HNT-1P).....	64
8.4. ACA MODE (ONLY IN HNT-1P).....	67
8.4.1 Enlarged ACA Image Screen.....	68
8.5. POWER SAVING MODE.....	69
9. MEASUREMENT	70
9.1. BEFORE CALLING FOR SERVICEMAN.....	70
9.1.1. Self diagnosis & Maintenance.....	70
9.2. REPLACEMENT.....	72
9.2.1 Printer paper.....	72
9.2.2 Chinrest paper.....	73
9.2.3 Replacing Fuse.....	74
9.3. CLEANING.....	74
9.4. AS CHANGING THE INSTALLATION PLACE OF THE EQUIPMENT.....	75
10. SERVICE INFORMATION	76
11. MANUFACTURER	77
12. EMC (ELECTROMAGNETIC COMPATIBILITY) INFORMATION	78
13. SPECIFICATIONS	80
14. ACCESSORIES	82

1

Introduction

1.1. Intended Use

The Non-Contact Tonometer HNT-1 is intended to be used to measure the intraocular pressure of the human eye. HNT-1P is also provided measurement of patient's central corneal thickness, as well as HNT-1's function.

1.2. Overview

The Non-Contact Tonometer HNT-1/1P is indicated for measuring intraocular pressure to aid in the screening and diagnosis of glaucoma.

Non-contact Tonometer HNT-1/1P measured intraocular pressure of both eye by Auto alignment function. In particular, when a lot of lights are sensed the moment that compressed air is separated, prescription about glaucoma is possible by system that convert time to mmHg intraocular pressure after measure microseconds.

Automatic and passivity compensation function of measurement by cornea thickness are possible, It supply optimum intraocular pressure information.

1.3. Classificaiton

- Classification of product : Class IIa according to Annex IX (Rule 10) of the Medical Device Directive 93/42/EEC as amended by 2007/47/EC
- Resistance against electric shock : Class I (earthed)
- Protection class against electric : Type B(Head rest, chinrest paper)



CAUTION

United States Federal law restricts this device to the sale, distribution and use by or on the order of an ophthalmologist or optometrist.

2

Safety Information

2.1. Overview

Safety is everyone's responsibility. The safe use of this equipment is largely dependent upon the installer, user, operator, and maintainer. It is imperative that personnel study and become familiar with this entire manual before attempting to install use, clean, service or adjust this equipment and any associated accessories. It is paramount that the instructions contained in this manual are fully understood and followed to enhance safety to the patient and the user/operator. It is for this reason that the following safety notices have been placed appropriately within the text of this manual to highlight safety related information or information requiring special emphasis. All users, operators, and maintainers must be familiar with and pay particular attention to all Warnings and Cautions incorporated herein.



WARNING

“Warning” indicates the presence of a hazard that could result in severe personal injury, death or substantial property damage if ignored.

**NOTE**

“Note” describes information for the installation, operation, or maintenance of which is important but hazard related if ignored.

**CAUTION**

“Caution” indicates the presence of a hazard that could result in minor injury, or property damaged if ignored.

2.2. Symbol Explanation

The International Electrotechnical Commission (IEC) has established a set of symbols for medical electronic equipment which classify a connection or warn of any potential hazards. The classifications and symbols are shown below.

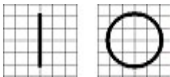

I and O on power switch represent ON and OFF respectively.



Type B Isolated patient connection.

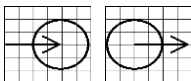

It indicates the connection of signal input/output.



This symbol identifies a safety note. Ensure you understand the function of this control before using it. Control function is described in the appropriate User's or Service Manual.



Hot surface.



Identifies the point where the system safety ground is fastened to the chassis. Protective earth connected to conductive parts of Class I equipment for safety purposes.



Manufacturer

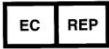

Authorised Representative in the European Community



Temperature Limitation



Keep DRY



Warning: Crushing or insert of hand

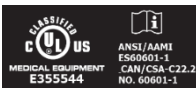

UL Mark



CE Mark

2.3. Environmental Considerations

Please avoid the environment below for the operation and storage of the equipment.



A place where the equipment can be exposed to water.
Do not operate the equipment with wet hand.

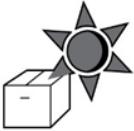

A place where the equipment can be exposed to direct sunlight.



A place where the equipment can be exposed to direct ultraviolet.

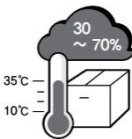

Where the temperature changes frequently (Normal temperature for operation of the machine is at the range of 10°C ~ 35°C, and the humidity is at the range of 30%~70%).

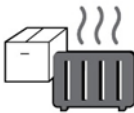

A place nearby a heating apparatus.



A place where the equipment can be exposed to water.
Do not operate the equipment with wet hand

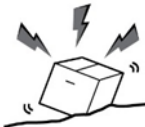

A place where the equipment can be exposed to excessive pressure or vibration.



A place where the equipment can be exposed to chemical substances or flammable gas.



Watch out for dust, especially metal pieces from entering the equipment.

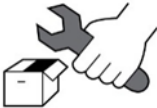

Do not disassemble the product.
Huvitz will not be held responsible for any negligence regarding such action.



Do not close the thermal ventilation outlet



Do not connect the AC power adapter before all parts are fully assembled. It can lead to a malfunction.



Always pull the power cord holding the plug and not the cord.

For the normal operation of the machine, please keep the ambient temperature is 10 °C ~ 35 °C, humidity is 30% ~ 90% and atmospheric pressure is 800 ~ 1060hpa. For the Transportation of the machine, please keep the ambient temperature is -40 °C ~ 70 °C, humidity is 10% ~ 95% and atmospheric pressure is 500 ~ 1060hpa. For the Storage of the machine, please keep the ambient temperature is -10 °C ~ 55 °C, humidity is 10% ~ 95% and atmospheric pressure is 700 ~ 1060hpa. Avoid environments where the equipment is exposed to excessive shocks or vibrations.

2.4. Safety Precaution

This equipment has been developed and tested in conformity with domestic & international safety standards and regulations, which guarantees the high stability of this product. This guarantees a very high degree of safety for this device. The legislator expects us to inform the user expressively about the safety aspects in dealing with the device. The correct handling of this equipment is imperative for its safe operation. Therefore, please read carefully all instructions before switching on this device. For more detailed information, please contact our Customer Service Department or one of our authorized representatives.

1. This equipment must not be used (a) in an area that is in danger of explosions and (b) in the presence of flammable, explosive, or volatile solvent such as alcohol, benzene or similar chemicals.
2. The device should neither be kept nor installed in the place with high humidity. For the optimal operation, the humidity should be at the range of 30%~75%. The machine should not be exposed to the place where water splashes, drips or sprays. Do not place containers containing fluids, liquids, or gases on top of any electrical equipment or devices
3. The equipment must be operated only by, or under direct supervision of properly trained and qualified person/s.
4. Modifications of this equipment may only be carried out by Huvitz's service technicians or other authorized persons.
5. Customer maintenance of this equipment may only be performed as stated in the User's Manual and Service Manual. Any additional maintenance may only be performed by Huvitz's service technicians or other authorized persons.
6. The manufacturer is only responsible for effects on safety, reliability, and performance of this equipment when the following requirements are fulfilled: (1) The electrical installation in the respective room corresponds to the specifications stated in this manual and (2) This equipment is used, operated and maintained according to this manual and Service Manual.



7. The manufacturer is not liable for damage caused by unauthorized tampering with the device(s). Such tampering will forfeit any rights to claim under warranty.
8. The equipment may only be used together with accessories supplied by Huvitz's. If the customer makes use of other accessories, use them only if there are usability under technical safety aspects has been proved and confirmed by Huvitz or the manufacturer of the accessory.
9. Only persons who have undergone proper training and instructions are authorized to install, use, operate, and maintain this equipment.
10. User's manual or service manual should be kept in the place where the persons in charge of operation and maintenance can access easily any time.
11. Do not force cable connections. If a cable does not connect easily, be sure that the connector (plug) is appropriate for the receptacle (socket). If you cause any damage to a cable connector(s) or receptacle(s), let the damage(s) be repaired by an authorized service technician.
12. Please do not pull on any cable. Always hold on to the plug when disconnecting cables.
13. This equipment may be used for the international application related to Tonometry according to this manual.
14. Before every operation, proceed with visual inspection on the equipment exterior to seek any mechanical damage(s) to ensure the proper functioning.
15. Do not obstruct any ventilation outlet for proper heat dissipation.
16. In case of any presence of smoke, spark or abnormal noise/smell from the machine, please power off immediately and pull out the plug.
17. IEC standard needs to be satisfied with in order to connect an outside device with input/output signal or other connector. (IT equipment is IEC 60950, and electric equipment for medical use is IEC 60601). Moreover, all the systems need to satisfy the safety requirement, IEC 60601-1-1 when it comes to the electric system for

medical use. Person who connects outside device with input/output signal or other connector has the obligation to take responsibility in accordance to the IEC60601-1-1. Contact local technician or distributor if you have doubts.

18. To avoid electrocution, this device must be connected to the supply power along with protective grounding.
19. Do not place at a difficult location when separating cable when it comes to the device's placement.
20. When you carry this product, please hold on left and right bottom of the product. If you want the product to be installed on another place, please call A/S center.

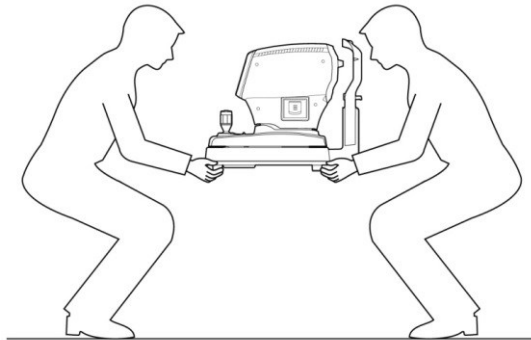



CAUTION

For use of equipment in rated voltage less than 125Vac, minimum 6A, Type SJT or SVT , 18/3AWG, 10A, max 3.0m long : One end with Hospital Grade Type, NEMA 5-15P Other end with appliance coupler. For use of equipment in rated voltage less than 250Vac, minimum 6A, Type SJT or SVT , 18/3AWG, 10A, max 3.0m long : One end terminated with blade attachment plug(HAR) Type, NEMA 6-15P.

This equipment must be installed and operated in accordance with provided instructions and the antenna(s) used for this transmitter must be installed to provide a separation distance of at least 20 cm from all persons and must not be co-located or operating in conjunction with any other antenna or transmitter. End-users and installers must be provide with antenna installation instructions and transmitter operating conditions for satisfying RF exposure compliance.

3

Charateristics

1. Distance between eye and device are established automatically to measurement position. (Working Distance : 11mm)
2. The peak of the air pressure is automatically controlled within the range of 0 to 60 mmHg.
3. Air pressure by pressure of patient's eye in controlled suitable.
4. With the enhanced SPC function, achieves a softer and quieter air puffing.
5. Confirm data amount and detection comparison between reference pressure and data.
6. Reduce error compensating measurement according to patient's cornea thickness.
7. It is provides the automatic calculation function of the compensated IOP based on the central corneal thickness.
8. Intraocular pressure of both eyes is measured by auto alignment function.
9. With auto-tracking and auto shot, HNT-1/1P allows easy and accurate measurement.
10. HNT-1P is the model combining non-contact tonometer and pachymeter in one unit.

4

Note for Use

1. Do not hit or drop the instrument. The instrument may be damaged by the strong impact. The impact may damage the function of this instrument. Handle it with care.
2. The precision of measurement can be affected when the machine is exposed to the direct sunlight or too bright indoor illumination. It is recommended to perform the measurement in the dark optometry room.
3. If you want to use it as connecting the device to other equipment, please follow the guidance of our local representative.
4. Sudden heating of the room in cold areas will cause condensation of vapor on the protective glass in the measurement window and on nozzle parts inside the instrument. In this case, wait until condensation disappears before performing measurements.
5. Make sure to keep the window in examinee side is clean at all times. In case that it has become dirty by dusts or other substances, it can cause errors in the machine or affect the precision of measurement.
6. In case of any presence of smoke, smell or noise during the use of machine, please contact our local representative after plugging it off from the socket (outlet).
7. If you clean the surface of the equipment with organic solvents such as alcohol, thinner, benzene, etc, it can damage the machine. So, please do not use them.
8. In case of moving Non-Contact Tonometer HNT-1/1P, carry it holding the lower part of machine body with both hands as fixing the stage after switching the machine off all the time.
9. In case of no use of the machine for a long time, please put the dust cover on the device after powering and plugging off.

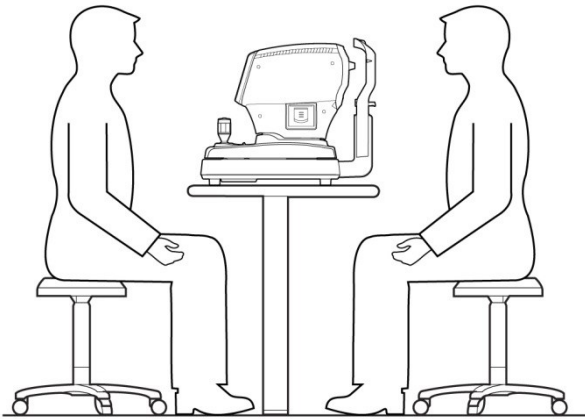

5

Names and functions of each part

5.1. Main Parts

Safe switch for protecting patient's eye will add in device

■ Front Part

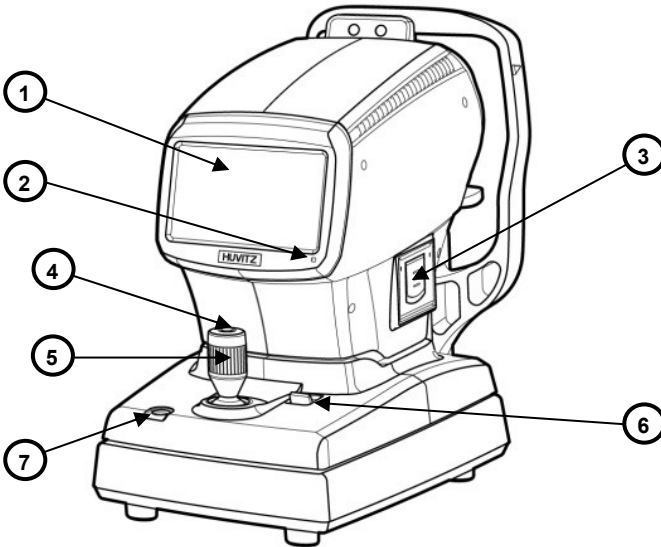

- ① **LCD Touch Screen** : Selectiong for measurement and function parts
- ② **Operation Lamp** : Indicates whether or not the electric power is on
- ③ **Printer** : Printing the measured results
- ④ **Measurement Button** : A button pressed on to measure

- ⑤ **Joystick Lever (Operation Lever)** : A lever for moving object to the front and back, left and right, and up and down
- ⑥ **Stage Fixation Lerver** : A lever for fixating stage
- ⑦ **Safety Button** : Safety distance establishment between patient and device

Back Part

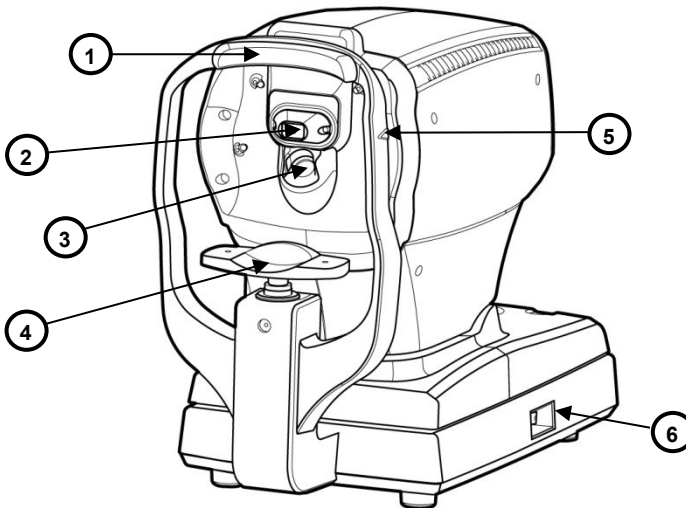

- ① **Forehead Rest:** Preventing the vibration by fixing the forehead.
 - ② **Air Nozzle:** Measuring the intraocular pressure on eyes.
 - ③ **Object lens for Pachy:** Object lens for measuring the cornea thickness of examinees.
(only in HNT-1P)
 - ④ **Chinrest:** Preventing the vibration by fixing the chin.
 - ⑤ **High Adjustment Mark:** Adjusts the eyes` height of examinees.
 - ⑥ **Power Switch:** Switch for power on/off
-

Bottom Part

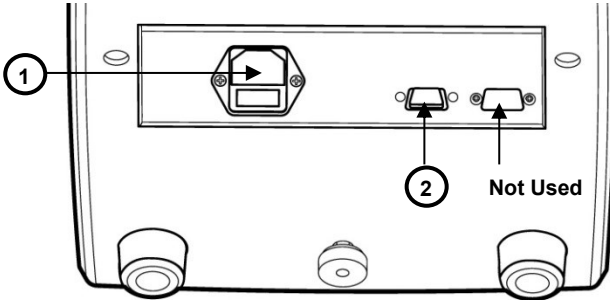

- ① **Power Supply Socket** : A socket connecting to exterior power plug
- ② **Serial Interface (RS-232C) Connector** : A terminal connecting to the exterior equipment. When exporting the measured data to an external computer with RS-232C connector, connect an interface cable here.

5.2. Explanation of Main Screen

5.2.1. Main Screen of HNT-1

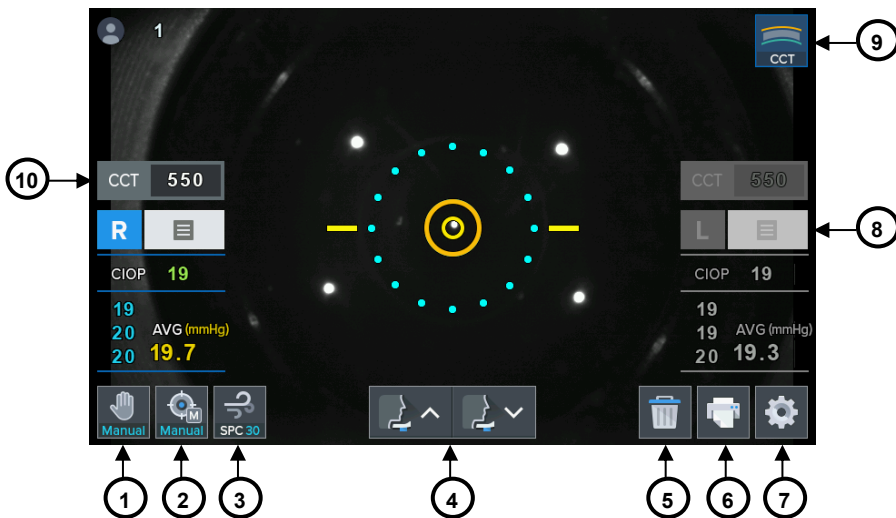

① **Manual** [Tracking Mode]

A toggle button to change the Tracking mode for measurement (MT / AT2D / AT3D)

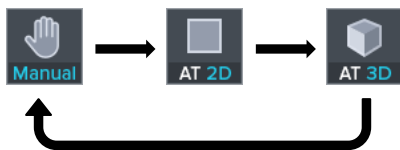

- ②  **[Shooting Mode]**

A toggle button to change the Shooting mode for measurement (MS / AS1 / AS3)



- ③  **[SPC Mode]**

A toggle button to change the SPC mode for measurement range (SPC30 / SPC60 / 30 / 60)



- ④  **[Chinrest Up/Down Button]**

Move up or down the chinrest

- ⑤  **[Clear Button]**

Clear measurement data

**NOTE**

Press and hold the Clear button for 2 ~ 3 seconds to result the head position.

**⑥ [Print Button]**

Print measurement result

**⑦ [Setting Button]**

Display the user SETUP screen

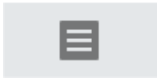
**⑧ [Result Button]**

Display all measurement data on the Result screen

**⑨ [Compensation mode Button of Cornea Thickness]**

Display the CCT(Central Cornea Thickness) value and CIOP(Compensated Intra Ocular Pressure) data

**NOTE**

Compensation mode button is the feature to display compensated IOP value manually input the CCT values. This button is not necessary in the HNT-1P, because it has the function of measuring CCT itself.



⑩ [CCT input button]

Display CCT input dialogbox to input cornea thickness.

Cornea thickness compensation is mode to input cornea thickness to device and gets correct data to measure exactly patient's intraocular pressure.

Input data of Cornea Thickness

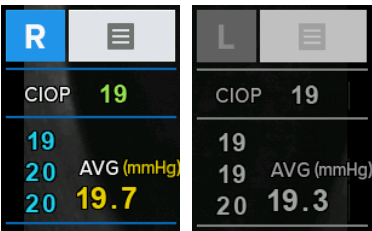

[IOP Measurement Data]

Display the CIOP, IOP data and IOP average of the last three data



[Patient Number (Counter)]

Show the patient measurement number

Focus Indicator

Divide into 7 steps by focus position.

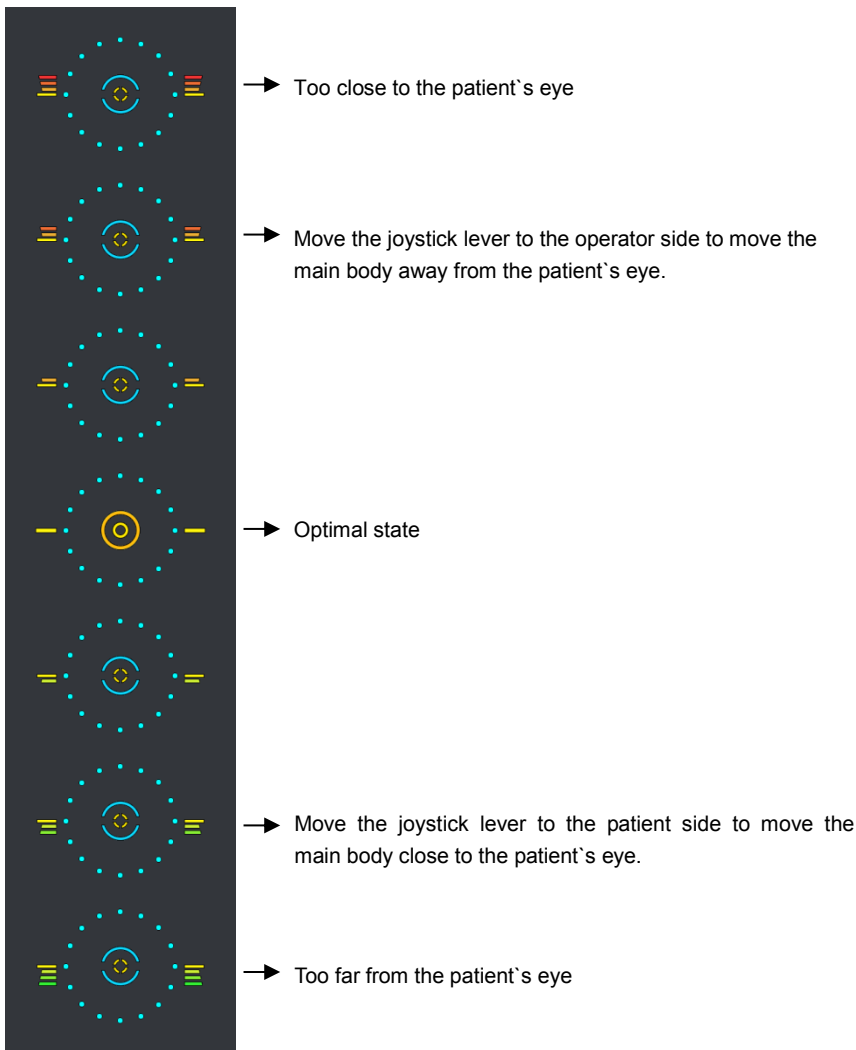

 **NOTE**

If the main body unit get out of the working range of auto tracking in the forward and backward, right and left, up and down, the indicator is displayed. According to the indication of the focus indicator, you can manipulate by joystick.



Move the joystick lever toward the patient



Move the joystick lever toward the operator



Move up by rotating the joystick lever to the clockwise



Move down by rotating the joystick lever to the counter clockwise



Move the joystick lever to the left



Move the joystick lever to the right

5.2.2. Main Screen of HNT-1P



① **TONO PACHY** [Measurement Mode]

A switch to change the measure mode (TONO / PACHY / TONO-PACHY)

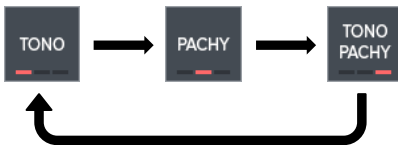

 **NOTE**

Measure mode button can be displayed differently depending on the setting of the Setup mode. According to “Mode Button Toggle” item of the SETUP mode,

if ‘ON’ is selected, it will appear only one toggle button such as .

Otherwise, it will appear three button such as .

“Mode Button Toggle” of the Setup mode

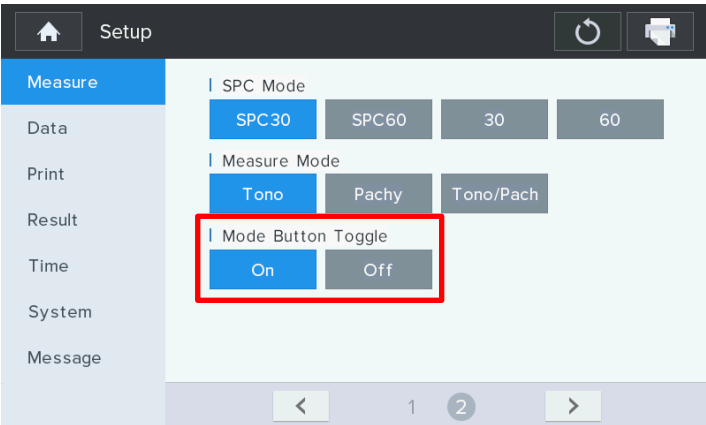

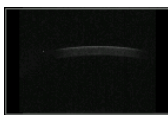

② [Pachy Thumbnail Button]

Display Pachy Image enlarged Screen (Refer to Section 8.3)



③ [ACA Mode Button]

Display ACA(Anterior Chamber Angle) mode screen (Refer to Section 8.4)

R	☰	L	☰
603		564	
592 AVG (μm)		564 AVG (μm)	
602 599.0		568 565.3	
CIOP 11		CIOP 14	
15		15	
AVG (mmHg)		AVG (mmHg)	
15.0		15.0	

④ [Pachy + IOP Measurement Data]

Display the Pachy data as well as CIOP, IOP data

Pachy and IOP data also shows the average of the last three data

6

Installation of Equipment & Preparation of Measurement

1. Release of Lock on Stage Section

Unlock the clamping bolt at the bottom of the machine by rotating it counterclockwise, and change the stage fixing lever behind the joystick to the direction of UNLOCK.

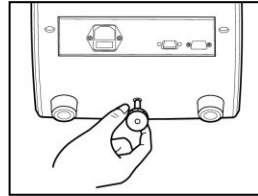

[Release of Lock on Stage Section]

2. Connection of Power Cable

- Put Non-Contact Tonometer HNT-1/1P on the table.
- Insert the power cable into power connector at the bottom of the main body.
- After checking that the power of the machine is off, insert the power plug into AC outlet (socket)

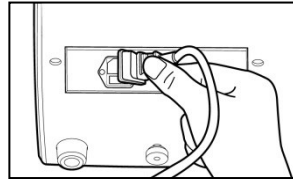

[Connection of power cable]

3. Inserting Chin Restpaper

- Pull out the pushing pins at left/right sides.
- Insert the pushing pins into the holes at left/right sides of the chin-rest paper.
- Stick the chin-rest paper inserted with the Pushing pins onto the chin-rest.

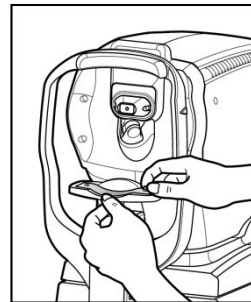

[Inserting chin-rest paper]

4. Installation of Printing Paper

Please refer to section 9.2.1 regarding the sequence of installation of Printing paper.

5. Input of Message

Input the contents desirable to be printed such as name or address of hospital, etc. in the memory of message editing monitor in advance at all times.

6. Check of Set up

As set up of patient counter, Auto Tracking, Auto Shooting, SPC mode, pressure measurement unit, ACC mode, Cornea thickness input, print mode, data, etc, please check them in SETUP mode. (refer to Section 8.1)

7. Transmission to Other Machines.

In case of transmitting the measured results to external computer, prepare external computer while connecting the cable into the interface connector of this machine. You can select the transmission On/Off in the user's SETUP mode. Please contact to the agent where you bought this machine for details.

7

Basic Operations

WARNING

If the following situations happen, contact to the agents of Huvitz after immediately pushing the power switch off, and pulling the power cord out of AC Power connection part.

- In case that smoke comes, or strange smell or sound is heard from the equipment.
- In case that liquid is poured to the machine, or metallic substance is inputted into the equipment.
- In case that the equipment is fallen down, or the exterior case of it is broken

NOTE

As the equipment does not operate for over 3 minutes while the power switch is at the state of "ON", the power saving mode is to be performed. If you push any buttons in the power saving mode, it is changed to the mode of measurement preparation.

7.1. Measurement

It is the mode to measure the intraocular pressure and pachymetry.

1. Let the power switch “on”

The measurement window as shown in the picture below appear on the screen of monitor as system check is completed.

■ Measurement Screen

- HNT-1



- HNT-1P



2. Check the measurement screen appeared on the monitor.

 **NOTE**

If the measurement screen as shown in the above picture does not appear on the monitor screen, let the power switch “ON” again in 10 seconds after switching it off. If the measurement screen continues not to appear either, please contact to the agents of Huvitz.

3. Check the user SETUP mode. (Refer to Section 8.1)

Check and select the diverse functions relating to measurement including intraocular pressure value or printing condition. Input the message wanted to be printed together with measurement data.

7.2. Manual Measurement Mode

As pushing toggle button  of the Tracking mode button, it changes to sequentially.

If you change “AT2D  / AT3D  ” to “MT  ”, it will operate in the manual measurement mode.

① Adjustment of eye height.

Let the examinee sit in front of the machine.



Make sure that the examinee should not put his or her hands or fingers under chin-rest. The hands or fingers can get injured.

For the prevention of infection, cleanse the forehead-rest with a solvent such as ethanol for every different examinee.

To keep it clean, change the chin rest paper for every different examinee.

- Let the patient sit comfortably by adjusting the table or chair or electric machine.
- Let the patient put his or her face on chinrest and his or forehead stick closely to the foreheadrest.
- Adjust the examinee's eye height to the height array indicator by pressing the chin rest up/down button in the touch screen.

② Adjustment of the safety distance between the examinee's eye and device

- Adjust the safety distance between the examinee's eye and device by pressing the safety button as shown in the picture.
- Adjust the safety distance between the examinee's eye and device so that the distance is 8 to 10 mm.

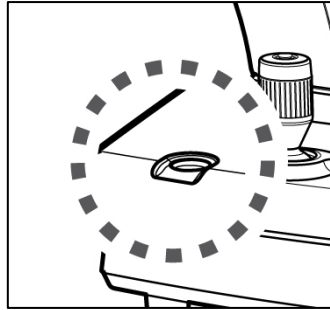

[Safety Button]

 **WARNING**

Be sure to check the safety distance before measurement.

If the safety distance is not secured, may touch and injury the examinee's eye.

③ Adjustment of Measurement Position and Focus.

 **CAUTION**

Do not insert your hands or fingers between stage and base. Also, make sure that the examinee should not put his or her hands or fingers there. Hands or fingers can get injured.

- Pull body of equipment to the front of user by using joystick lever.
If necessary, after secure a safety space so that the air nozzle does not the patient's

eye, use to Safety button.

- Left the right side eye of examinee appears at the center of monitor screen by slowly pushing and rotating joystick lever. At this time, let the glittering bright dot come into the core of internal array ring.
- Ask the examinee to look at internal fixed target (green led).
- Adjust the focus so that the outline of bright dot can be apparent. If the focus is adjusted appropriately, the circle symbol appears on the bright dot.
- Height Adjustment: Adjust it by rotating joystick lever or chinrest button in the touch screen.
- Left/Right Adjustment: Move the operation joystick lever left and right so that outer alignment ring is aligned with the circle ring.
- Focus Adjustment: Adjust it to the bright dot by tilting the operation joystick lever forward/backward.

Manual mode Measurement Screen

- HNT-1



NOTE

As the bright dot and pupil can not keep the same axis during the consecutive measurement, the error can be caused for measurement.

④ Measurement

- Push the measurement button on the joystick lever.
- Used to choose among 1 time(AS1), 3 times(AS3) and manual(MS) automatically in “Auto Shooting” mode in user SETUP mode and Measurement screen before taking measurement.
- As the measurement is completed, the measured result is to be indicated on the

screen of monitor.

- In case of the consecutive measurement, the result of the previous measurement is indicated.

⑤ Repeated Measurement

- Measure repeatedly if necessary.
- The latest measured value is to be indicated every time new measurement is performed.
- It shall memorize the measured values by 10 times for each left/right eye (except for error). It can be seen on the screen of Result mode.

⑥ Measurement of Counter-side eye

- After measure the right-side eye, measure the left-side eye to the direction of right by operation the joystick lever.
- As measuring the left/right eyes, the value of intraocular pressure is to be indicated on the screen. In the case of HNT-1P, according to the measurement mode(Tono / Pachy / Tono-Pachy), measured values are displayed differently.
- Measurement can be done by continuing and the last three of data sets used for the averaging is displayed of the average data on the measurement screen. (Right /Left eye). On the Result mode screen, the last 10 of data sets is diplayed sequentially.



Data List of Result Screen

Data List		mmHg						
	R	IOP	CCT	CIOP	L	IOP	CCT	CIOP
	1	21	_____	21	1	20	_____	20
TONO	2	20	_____	20	2	21	_____	21
	3	21	_____	21	3	20	_____	20
	4				4			
PACHY	5				5			
	6				6			
	7				7			
TONO	8				8			
PACHY	9				9			
	10				10			
	AVG	20		20	AVG	20		20

⑦ Print

- Print the measured result by pushing the PRINT button.
- The contents selected in SETUP mode is to be printed.
- Cut the printing paper off from the end of it while lifting it.
- Put the name of examinee in the blank of NAME if necessary.



NOTE

As it is printed, the values measured so far are to be removed.

As a thermal printing record, the printed characters are easy to be faded away.
Please make it copied if you want to keep it for a long time.

■ Example of Print

- Printed page of HNT-1

```
NAME :  
DATE : 2016/09/06 11:38  
No. 0001  
HUVITZ HNT-1  
Ver 0.1.0  
  
IOP      <R>      <L>  
-----  
          19      20  
          18      20  
          19      19  
  
AVG      -----  
          18      19  
  
CIOP     <R>     <L>  
-----  
          19      20  
          18      20  
          19      19  
  
AVG      -----  
          18      19  
  
Huvitz Co., Ltd.  
+82-31-428-9100
```



7.3. Auto Measurement Mode



As pushing toggle button **Manual** of the Tracking mode button, it changes to sequentially.



If you change “MT **Manual**” to “AT2D **AT 2D**” or AT3D **AT 3D**”, it will operate in the Auto measurement mode.

AT2D mode: Auto tracking in the right and left up and down directions is activated.

AT3D mode: Auto tracking in the forward and backward, right and left, up and down directions is activated.

As the condition of good array between the machine and the measured eye is reached, the measurement is to be performed automatically without pushing the measurement button.

- ① Perform the ①, ② and ③ procedure of section 7.2 Manual Measurement Mode
- ② Measurement
 - As the array and adjusting the focus is completed, the measurement is to be performed automatically.
 - After the measurement of times (AS1(1times), AS3(3times) or MS(manual measurement) designated in user SETUP mode is performed, the measured result appear on the screen of monitor.
 - For each side of eyes-left and right, maximum of the last 10 of data is to be stored, and you can re-check them in Result mode.

Auto Mode Measurement Screen

- HNT-1P



③ Measurement of Another Eye

- Measure the left eye according to the same procedure by moving the stage to the right side.
- As the measurement to both eyes is completed, the value of intraocular pressure is to be indicated on the screen. In the case of HNT-1P, according to the measurement mode(Tono / Pachy / Tono-Pachy), measured values are displayed differently.

④ Print

- Push the PRINT button in case that the measurement is conducted to the one eye only.
- In case of selecting the condition of Print as "Auto Print - ON" in SETUP mode the measured result is to be printed automatically as the measurement of both eyes is completed.

“Auto Print” of the Setup mode

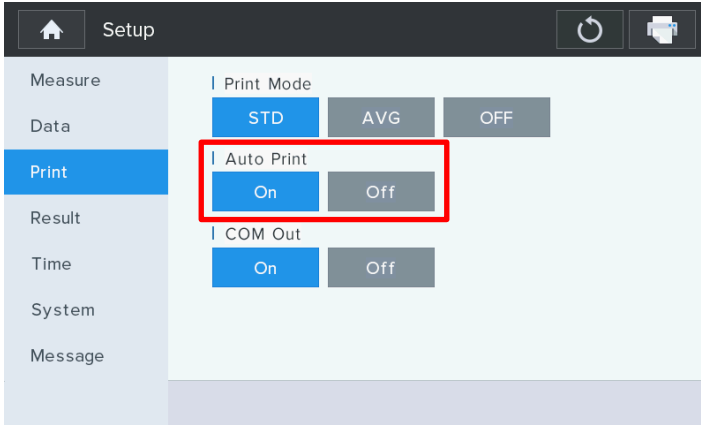

- The message selected in SETUP mode is to be printed together with the measured data.

■ Example of Print

- Pachy mode of HNT-1P

```
NAME :  
DATE : 2016/09/06 12:02  
No. 0003  
HUVITZ HNT-1P  
Ver 0.1.0  
  
[PACHY mode]  
CCT <R> <L>  
-----  
554 555  
553 554  
554 555  
AVG -----  
553 554  
  
Huvitz Co., Ltd.  
+82-31-428-9100
```



- Tono mode of HNT-1P

```
NAME :  
DATE : 2016/09/06 12:01  
No. 0001  
HUVITZ HNT-1P  
Ver 0.1.0  
  
[TONO mode]  
IOP <R> <L>  
-----  
      20    18  
      19    20  
      19    20  
  
AVG -----  
      19    19  
  
CIOP <R> <L>  
-----  
      20    18  
      19    20  
      19    20  
  
AVG -----  
      19    19  
  
Huvitz Co., Ltd.  
+82-31-428-9100
```

- Tono-Pachy mode of HNT-1P

```
NAME :  
DATE : 2016/09/06 12:02  
No. 0002  
HUVITZ HNT-1P  
Ver 0.1.0  
  
[TONO-PACHY mode]  
IOP <R> <L>  
-----  
      20    18  
      19    20  
      19    20  
  
AVG -----  
      19    19  
  
CIOP <R> <L>  
-----  
      20    18  
      19    20  
      19    20  
  
AVG -----  
      19    19  
  
CCT <R> <L>  
-----  
      554    555  
      553    554  
      554    555  
  
AVG -----  
      553    554  
  
Huvitz Co., Ltd.  
+82-31-428-9100
```

8

Other Modes

8.1. SETUP Mode

It is to perform many setups relating to measurement, print-out, etc. As pushing Set up



Button on the measurement screen, it entered SETUP mode.

■ Setup mode Information (Measure – 1Page)

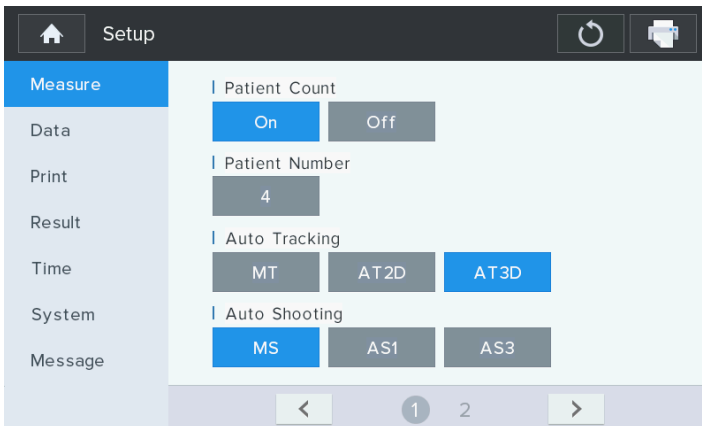





[How to Change Tab]

As pushing left side's tab button, it is to enter the tab items.

How to

[How to Change Page]

As pushing bottom side's arrow button   or page button  , it is to enter the next page.

[How to change item and content]

Select the wanted item on the Screen, and to change he setting by touching on the category to be modified.



Some need to be modified by using a different method. This setting modification procedure is instructed below the explanation for each category.



[Exit Button]

As pushing Exit button, return to the main measurement screen.



[Reload Button]

As pushing Reload button, revert to original values of all over the pages.



[Print Button]

As pushing Print button, print the all over setup values.

- **Patient Count** : Patient measurement count On/Off
- **Patient Number** : Measurement patient number
- **Auto Tracking** :

- MT - Manually align the device and bring the eye into focus.
- AT2D (X, Y) - Right and left, up and down direction (Auto)
- AT3D (X, Y, Z) - Forward and backward, right and left, up and down direction on one side.

■ Auto Tracking (MT, AT2D, AT3D)

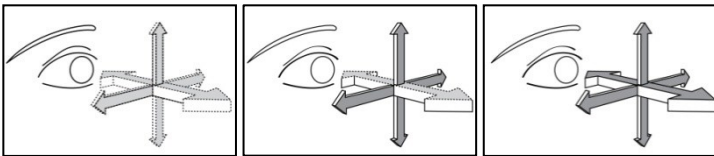

- Auto Shooting:

- MS - Manual shot by measurement button
- AS1 - 1 times auto shot
- AS3 - 3 times consecutive auto shots

■ Setup mode Information (Measure - 2Page)

- HNT-1

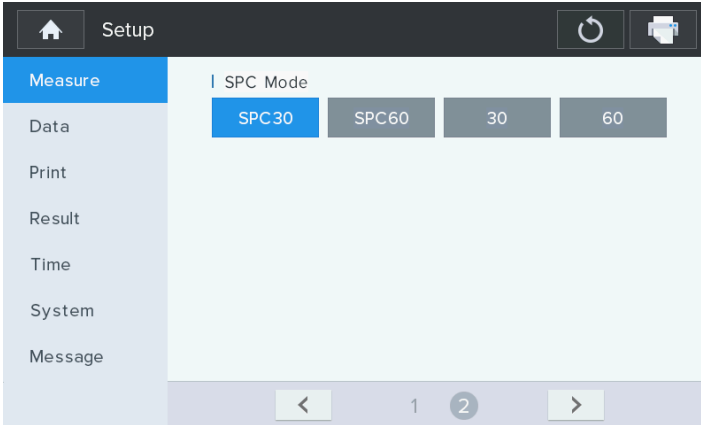

- HNT-1P

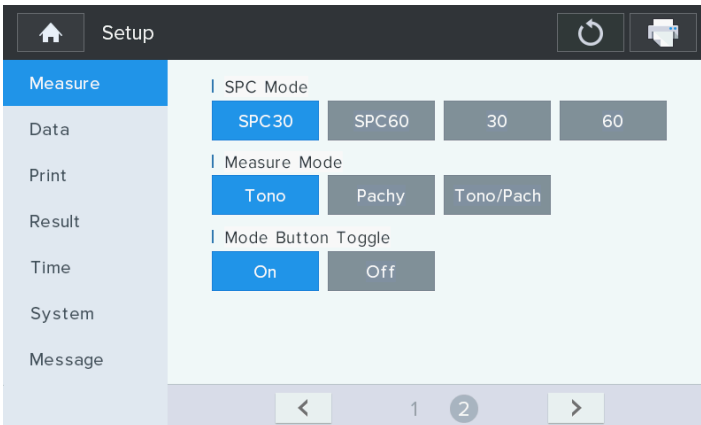

- **SPC Mode** : Air Pressure automatic measurement by patient's intraocular pressure.
 - **SPC 30** : The peak of the air pressure is automatically controlled within the range of 1 to 30 mmHg
 - **SPC 60** : 30 mmHg or more of intraocular pressure.
 - **30** : The peak of the air pressure is fixed within the range of 1 to 30 mmHg
 - **60** : The peak of the air pressure is fixed within the range of 1 to 60 mmHg
- **Measure Mode(Only in HNT-1P)** :
Selects a measurement mode from Tono / Pachy / Tono-Pachy.
- **Mode Button Toggle(Only in HNT-1P)** :
Differently display measure mode button on the Main Screen.

if 'ON' is selected, it will appear only one toggle button such as . Otherwise,

it will appear three button such as



■ Setup mode Information (Data - 1Page)

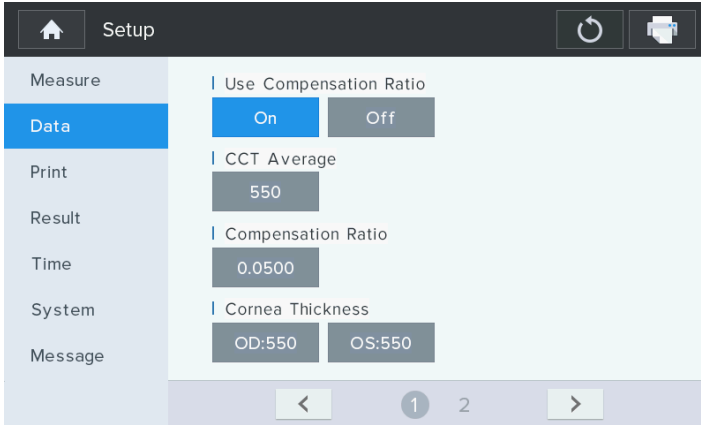

- **Use Compensation Ratio** : Set whether Corneal Thickness compensation should be applied or not.
- **CCT Average** : Setup of average value for Cornea Thickness(as reference)
- **Compensation Ratio** : Setup of Compensation ratio(0.0001~1.0000)
- ✓ **CIOP(Compensated Intraocular Pressure) Formula**

$$\text{Compensation factor} = (\text{CCT Average} - \text{Pachy data}) \times \text{Compensation Ratio}$$

$$\text{CIOP} = \text{IOP data} + \text{Compensation factor}$$

NOTE

If you select 'Off' for 'Use Compensation Ratio', 'CCT Average' and 'Compensation Ratio' item are displayed so that it can not be set. At this time, the CIOP value displayed on the Main measurement screen is displayed with the same value as the IOP value.

- **Cornea Thickness** : Input data of Cornea Thickness (Left/Right)

Input data of Cornea Thickness

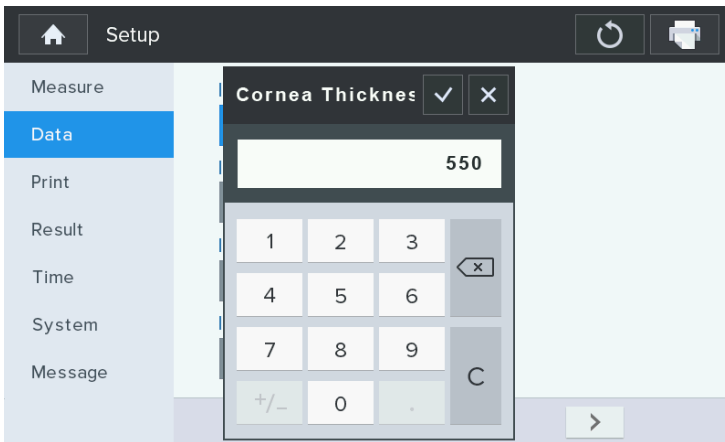

Setup mode information (Data – 2Page)

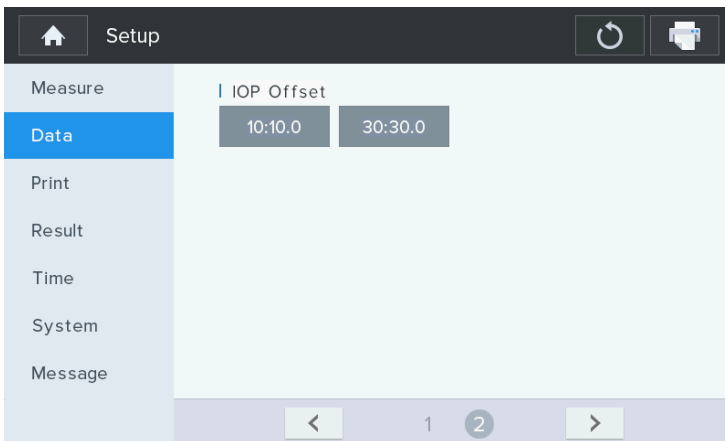

- **IOP Offset** : Setup of IOP offset value.

Setup mode information (Print)

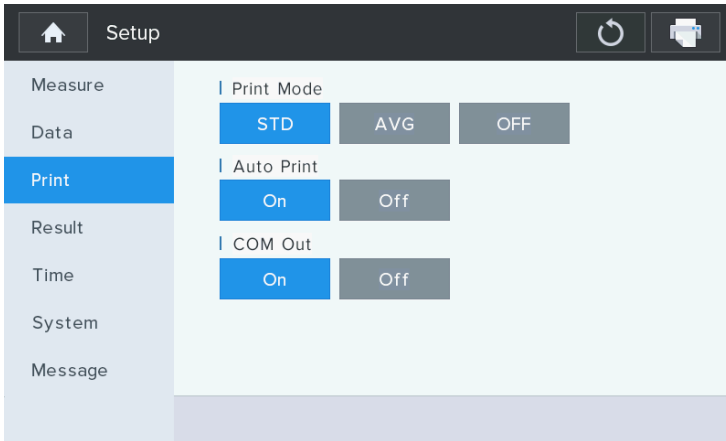

- **Print Mode :**
 - **STD :** The measured result & built-in printer of max ten (10) times are to be printed out
 - **AVG :** Only average value is to be outputted printed out
 - **OFF :** It is not to be printed out
- **Auto print :** In case of measuring in Auto mode, it is to print out the measured result automatically as the each measurement to left / right eyes is completed one after the other.
- **COM Out :** Setup of transmission on/off(Communication to other machines)

Setup mode information (Result)

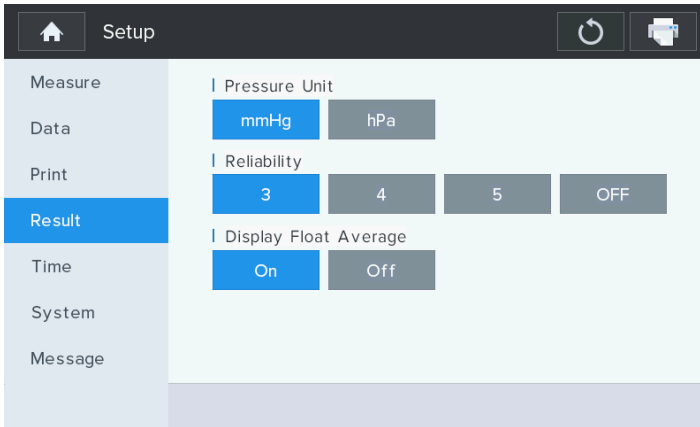

- **Pressure Unit** : Selection of pressure unit (mmHg, hPa)
- **Reliability** : Set the reliable offset to remove unreliable IOP measured data. If any IOP measured data is out of reliable range (IOP measured average - reliable offset, IOP measured average + reliable offset), then it is considered unreliable. Unreliable data are marked with an '*' on the printed result, and they are excluded from calculating IOP average. If OFF is selected, checking reliability of IOP measured data is disabled.
- **Display Float Average** : Set the floating point display of average value. If you select 'On', display the floating point.

Setup mode information (Time)

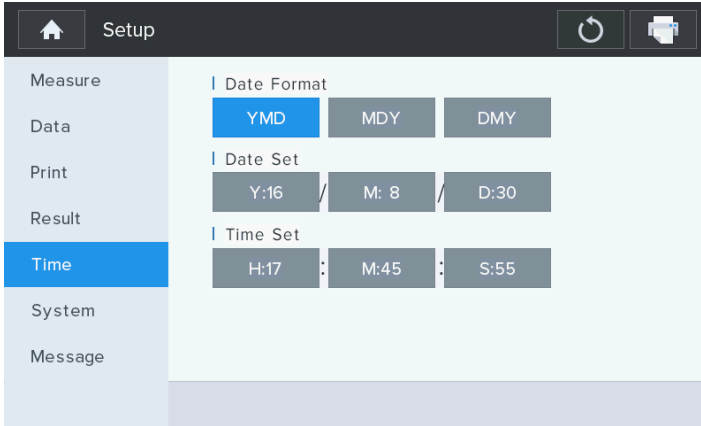

- **Date Format:** Set up of indication sequence of year/month/date
- **Date Set:** Set of Y(Year)/M(Month)/D(Day)
- **Time Set:** Set of H(Hour)/M(Minutes)/S(Second)

■ Setup mode information (System- 1Page)

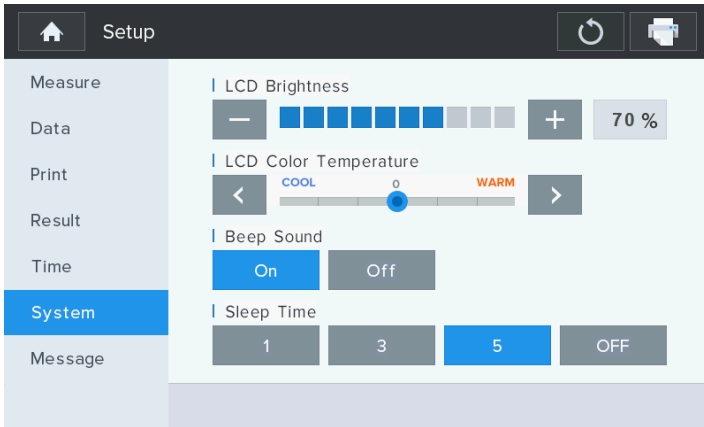

- **LCD Brightness** : Adjust Brightness of LCD panel (10% ~ 100%).
- **LCD Color Temperature** : Adjust Color Temperature of LCD panel (Cool-Warm 7step).
- **Beep Sound** : Set up Beep sound (on/off), Electric beeper sound is occurred when the touch button is pressed and the measurement button is pressed. If it is normal, it sounds only once, If it can't be measured, it sounds twice in succession.
- **Beep Volume** : Set the beep sound volume. You can increase or decrease the volume by pressing the plus or minus buttons.

Setup mode information (System- 2Page)

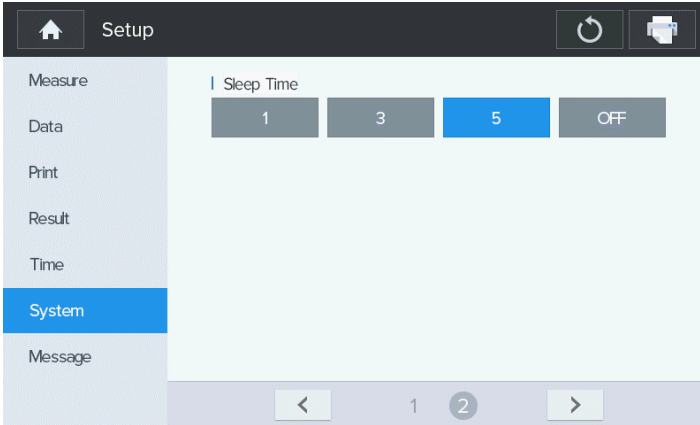

- **Sleep Time:** Set the sleep time in minute for sleep mode to be turned on. If any user input doesn't happen during the sleep time chosen, HNT system enters into sleep mode. (LCD monitor is turned off, front LED light flickers to notify that HNT system is in sleep mode). If OFF is selected, sleep mode is disabled.

■ Setup mode information (Message)

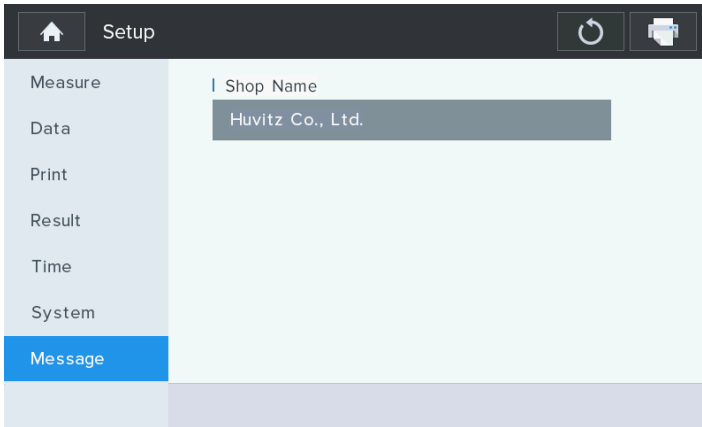

■ Virtual Keyboard

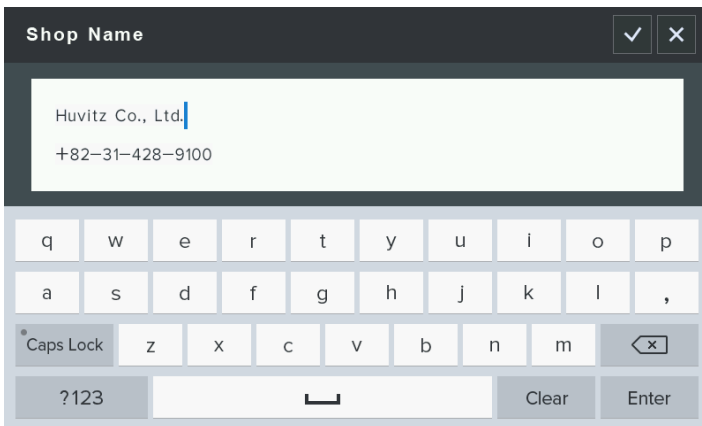



[Character Input]

Clear : Erase of all input.





 : Erase of text.

 : Change of line.

 : Change of uppercase page.

 : Change of number and special character page.

 : Save of information.

 : Exit without save.

8.2. Result Mode

You can see the measured results (Max ten(10) units of data) stored in memory in this

mode. As pushing R/L



button in the measurement mode, it can see measurement data.



NOTE

As pushing print button, the measured result stored in memory is to be printed out through the built-in printer, and it is removed completely for the new measurement

- It indicates measured Result of Intraocular Pressure, as well as CCT and CIOP value.
- It indicates the latest measured result of max amount of ten (10) times (Intraocular Pressure of left/right eyes).



Result mode Screen

- HNT-1

Data List		mmHg					
R	IOP	CCT	CIOP	L	IOP	CCT	CIOP
1	19	550	19	1	20	550	20
2	20	550	20	2	21	550	21
3	18	550	18	3	19	550	19
4				4			
5				5			
6				6			
7				7			
8				8			
9				9			
10				10			
AVG	19	550	19	AVG	20	550	20

- HNT-1P

Data List		mmHg						
	R	IOP	CCT	CIOP	L	IOP	CCT	CIOP
TONO	1	21	————	21	1	20	————	20
	2	20	————	20	2	21	————	21
	3	21	————	21	3	20	————	20
PACHY	4				4			
	5				5			
	6				6			
	7				7			
TONO PACHY	8				8			
	9				9			
	10				10			
	AVG	20		20	AVG	20		20

**NOTE**

In case of HNT-1P, Data list are divided into each of the measurement mode as Tono, Pachy and Tono-Pachy. Measured data at each measurement mode is entered separately. It can be confirmed by pushing mode items on the left side.

**[Exit Button]**

As pushing Exit button, return to the main measurement screen.

mmHg

hPa

[Unit Button]

As pushing Unit button, change to value of measured IOP data.(mmHg <->hPa)

**[Clear Button]**

As pushing Clear button, clear the all measurement data.

**[Print Button]**

As pushing Print button, print the all over measurement data.

8.3. Pachy Image Mode (Only in HNT-1P)

In case of HNT-1P, If you measure the pachy data, you can see a thumbnail of a corneal slit image captured at the upper left corner of the measurement screen. The corneal slit image at last measurement is saved to memory with the measurement data.

■ Tono-Pachy measurement Screen

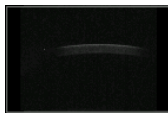

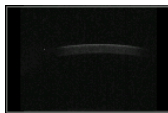
When this thumbnail image button  is pressed, it entered Pachy Image mode screen. In the Pachy Image mode, you can see a larger pachy image. Pachy Image and average data are displayed according to the measured position of Right/Left side.

Pressing Fitting button , it is displayed the detected edge area. Depending on the color indicates the separation of the anterior, posterior of the cornea.

■ Pachy Image mode Screen

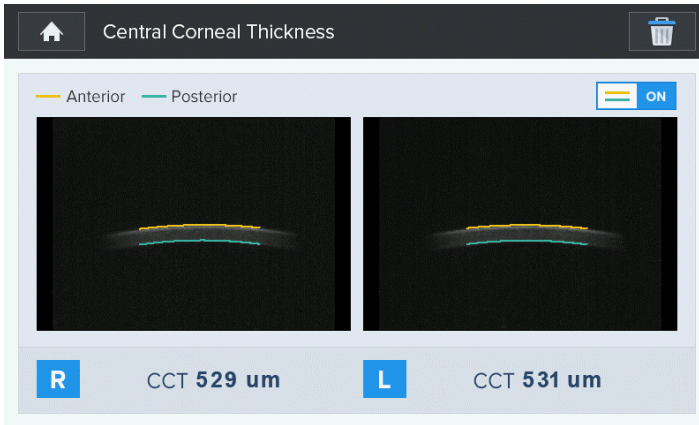

[Exit Button]

As pushing Exit button, return to the main measurement screen.



[Fitting Button]

As pushing Fitting button, display detected edge area of the cornea.



[Clear Button]

As pushing Clear button, clear the measured image and data.

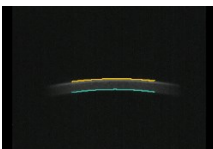

[Press Pachy Image]

As pushing Pachy image, enter enlarged pachy image screen.

■ Enlarged Pachy Image Screen

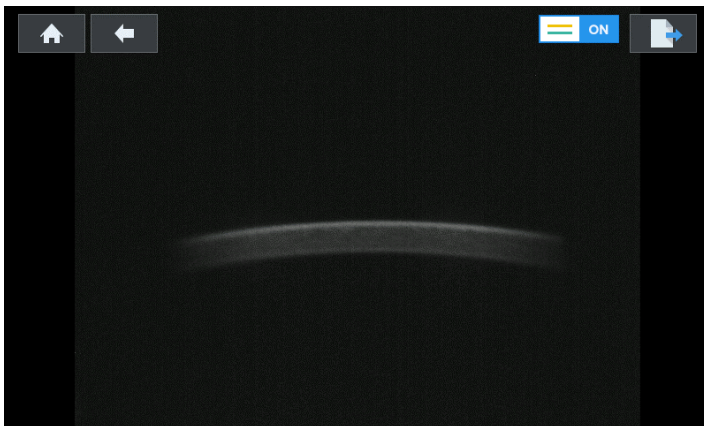

[Exit Button]

As pushing Exit button, return to the main measurement screen.



[Back Button]

As pushing Back button, return to the pachy image mode screen.



[Send Button]

As pushing Send button, send the pachy image to PC.



[Fitting Button]

As pushing Fitting button, display detected edge area of the cornea.

8.4. ACA Mode (Only in HNT-1P)

In case of HNT-1P, it has another feature of pachymetry. That's the ACA(Anterior Chamber Angle) function. The anterior chamber is the fluid-filled space inside the eye between the iris and the cornea's innermost surface. Glaucoma is main pathologies in this area. In glaucoma, blockage of the canal of schlemm prevents the normal outflow of aqueous humor, resulting in accumulation of fluid, increased intraocular pressure. Therefore, by measuring the anterior chamber angle of the cornea it can be found to increase the degree of intraocular pressure.



As pushing ACA button in the measurement mode, it can see ACA mode screen. On the left side of the ACA mode screen, showing the camera live image of the front of the eye. On the right side, showing the ACA live image. If it align the measuring unit to the position where the anterior chamber is displayed clearly by moving joystick lever, push the measurement button on the joystick lever. According to the measured position of Right/Left side, it is displayed captured image on the bottom right of the ACA mode screen.

■ ACA mode Screen

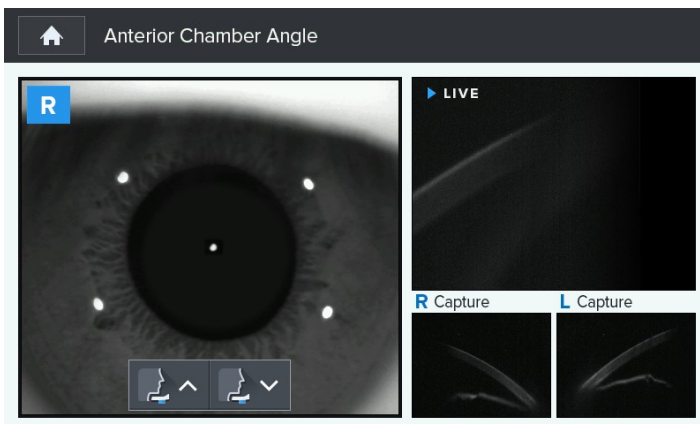

8.4.1 Enlarged ACA Image Screen

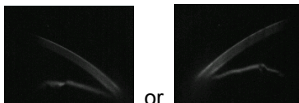

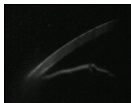
When this captured thumbnail image button  or  is pressed, it entered ACA Image screen. In the ACA Image screen, you can see a full ACA image.

Pressing Angle tool button , and measure angle by touching the screen with three points of the angle sequentially. it is displayed the angle value on the bottom right of the screen.

ACA Image Screen

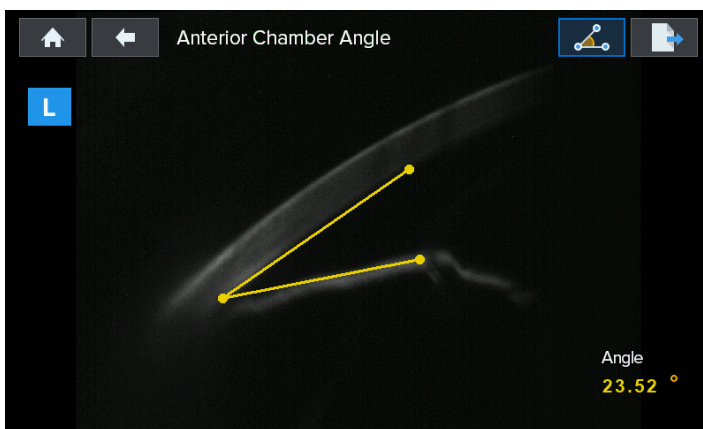

[Exit Button]

As pushing Exit button, return to the main measurement screen.



[Back Button]

As pushing Back button, return to the ACA mode screen.

**[Angle tool Button]**

As pushing Angle tool button, measure angle by touching the screen with three points.

**[Send Button]**

As pushing Send button, send the ACA image to PC.

8.5. Power saving Mode

The power saving function begins to operate if you do not operate the machine at all for three (1/3/5) minutes or so. It is to return to the measurement mode as pushing any button or touch optionally in saving mode. It is possible to adjust the power saving time when you select the "Sleep Time" on the user SETUP mode.

■ "Sleep Time" of the Setup mode

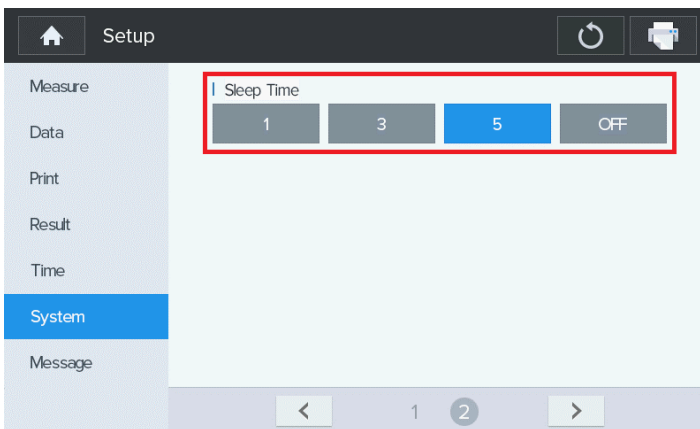



9

Measurement

9.1. Before calling for serviceman

In case that abnormality happens or the machine operates abnormally, a warning sign is to be indicated. In this case, perform the settlements below.

If the machine does not return to the normal condition in spite of the measures below, contact to the agent where you bought the machine after switching the power off.

9.1.1. Self diagnosis & Maintenance

Message	Method of Settlement
HEAD FRONT END	Optical head is position at fore-end of drive extent. For additional joystick lever forward operating.
HEAD REAR END	Optical head is position at back-end of drive extent. For additional joystick lever back operating.
HEAD RIGHT END	Optical head is position at right-end of drive extent. For additional joystick lever right operating.
HEAD LEFT END	Optical head is position at left-end of drive extent. For additional joystick lever left operating.
HEAD UPPER END.	Optical head is position at up-end of drive extent. Operating joystick lever upward or Chin-rest down transfer.
HEAD LOWER END	Optical head is position at down-end of drive extent. Operating joystick lever down or Chin-rest upward transfer.

SAFETY LOCKED	There is optical head in position that Safety lock established.
NO TARGET	There is no target.
EYE NOT FOUND	As measured, eye position is not align clearly
EYELID COVERED	As measured, eyelid was shield.
APPL WEAK	Applanation signal is feeble.
APPL OVER	Applanation signal is over
IOP INVALID	IOP is not measured normally.
IOP OVER	The intraocular pressure exceeds the preset measurement range.(IOP) Touch the measurement range to “spc 60” or “60” and perform the measurement again.
WEAK PRESS	Pressure of solenoid is weak.
SETUP INVALID	Do not setup for IOP measurement.
IMAGE NOT FOUND	The detection of the corneal thickness area is not available.
IMAGE INVALID	The detection area to draw converted coordinate is not valid.
KERATO INVALID	The calculation of the kerato value is not valid for compensation.
PACHY INVALID	Pachy is not measured normally
P-SETUP INVALID	Do not setup for Pachy measurement



9.2. Replacement

9.2.1 Printer paper

As red line appears on the paper, immediately change the print paper with new one.

- ① Open the printer cover
- ② Cut the paper inserted in the printer, and take it away from it. Take paper roll together with shaft out of the printer, and pull the rotating shaft away from paper roll.
- ③ Put the rotating shaft in to the new roll.
(Paper Thickness: 65 um, 58 mm (W) X 60 mm (H))
- ④ Put the paper inserted with the rotating shaft into the printer case.
- ⑤ Fix the paper onto the printer. At this time, adjust the length of paper so that it can come out from the paper outlet of the printer cover.
- ⑥ Close the cover after inserting the end of paper into the hole of cover.

■ Replacement Paper

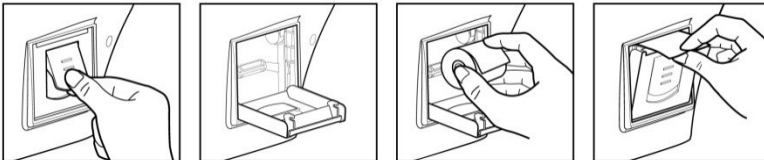

9.2.2 Chinrest paper

- ① Pull two(2) pins out of the chinrest.
- ② Push the pins into the holes of chinrest paper. You can put 50 sheets of it on. (130 mm X 40 mm , Hole : 5 mm)
- ③ Insert the pins into each one of two (2) holes in the chinrest.

■ Replacement Chinrest paper

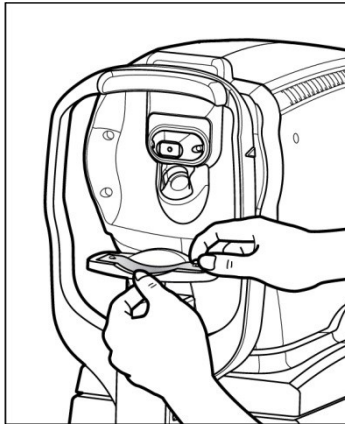

NOTE

Please use the chinrest paper that provided by Huvitz Co.,Ltd.



9.2.3 Replacing Fuse

- ① Turn off and raise the Non-Contact Tonometer HNT-1/1P with two arm carefully.
- ② Remove the Power cord
- ③ Pick the fuse holder out from the Power inlet
- ④ Exchange the fuses
- ⑤ Insert the fuse folder

9.3. Cleaning

- ① The Equipment should be kept as clean basically. Do not use the solvents such as strongly volatile substance, thinner, benzene, etc.
- ② Put some soapy water to the soft cloth, and twist the water out of the colth. Then, polish each part of the equipment. (RcooNA , NaOH, potash..)
- ③ As polishing the parts of lens or glass, get rid of dusts on the surface of lens with air tube and use a dry cloth.

9.4. As changing the installation place of the equipment

- ① Off the power switch of main body.
- ② Take the power connection cable apart.
- ③ Move it while maintain the horizontality of it by holding the bottom of the main body.

10

Service Information

Repair: If the problem is not solved in spite of the settlement according to the contents of chapter 9, please contact to Huvitz's agent with the information on the following items.

- Name of Equipment Type: Non-Contact Tonometer HNT-1/1P
- Typical No.of Equipment: Typical number consisted of 8 digits and characters written on its name plate.
- Explanation on its symptom: Description in detail.

Supply of parts required for repair:

- The preservation period of parts required for repair of this machine is by eight (8) years after stopping to produce the product.

Parts to be repaired by qualified service manpower:

- Parts below aer consumable in their characteristics, or the quality of them shall degraded after the long time use. User should not replace them by him or herself. Please contact to Huvitz's agent for the replacement if these parts are consumed enough or degraded by the longtime use.
- Back up battery for clerk and data.



CAUTION

As this machine use lithium battery, the reckless abandon of the machine itself or the lithium battery can cause the environmental pollution. Please contact to the professional waste disposal company.

11

Manufacturer

■ How to Contact HUVITZ Co., Ltd

38, Burim-ro 170beon-gil, Dongan-gu, Anyang-si, Gyeonggi-do, 14055, Republic of Korea

Tel: 031-428-9100 (Primary)

Fax: 031-477-9022(C/S)

<http://www.huvitz.com>

e-mail: svc@huvitz.com

■ EU Representative

Medical Device Safety Service GmbH (MDSS)

Schiffgraben 41, 30175 Hannover, Germany

Tel: +49-511-62628630

Fax: +49-511-62628633

12

EMC (Electromagnetic Compatibility) Information

Manufacturer announcement – electromagnetic waves trouble

- **Electromagnetic waves trouble**

HNT-1/1P should be used in the below mentioned electromagnetic wave environment. HNT-1/1P purchaser or user needs to confirm whether HNT-1/1P is used in this type of environment.

Trouble test	Question of appropriateness
RF emissions CISPR 11	Group 1
RF emissions CISPR 11	Class B
Harmonic emissions IEC 61000-3-2	Class A
Voltage fluctuations/flicker IEC 61000-3-3	Complies

- **Electromagnetic waves tolerance**

HNT-1/1P is to be used in the below designated electromagnetic wave environment. HNT-1/1P customer and user need to guarantee that the HNT-1/1P will be used in this type of environment.

Tolerance test	IEC 60601 test level	Appropriateness level
Electrostatic discharge(ESD) IEC 61000-4-2	contact ± 8 kV in the air ± 15 kV	contact ± 8 kV in the air ± 15 kV
Electric rapid transients/bust IEC 61000-4-4	power supplying line ± 2 kV input/output line ± 1 kV	power supplying line ± 2 kV input/output line ± 1 kV

Surge IEC 61000 – 4 – 5	between lines ± 1 kV between line and grounding ± 2 kV	differential mode ± 1 kV common mode ± 2 kV
Voltage dip, instantaneous interruption, voltage fluctuation at the power input line IEC 61000 – 4 – 11	For 0.5 cycle < 5 %UT(UT's > 95 % decrease) For 5 cycle, 40 % UT(UT's 60 % decrease) For 25 cycle, 70 %UT(UT's 30 % decrease) For 5 seconds < 5 % UT(UT's > 95 % decrease)	For 0.5 cycle < 5 %UT(UT's > 95 % decrease) For 5 cycle, 40 % UT(UT's 60 % decrease) For 25 cycle, 70 %UT(UT's 30 % decrease) For 5 seconds, < 5 %UT(UT's > 95 % decrease)
Power frequency magnetic field (50/60 Hz) IEC 61000 – 4 – 8	30 A/m	30 A/m
Other UT is the a.c. power voltage for before approving the test level.		

• **Electromagnetic waves tolerance**

HNT-1/1P is to be used in the below mentioned electromagnetic wave environment. HNT-1/1P purchaser or user needs to confirm whether HNT-1/1P is sued at this environment.

Tolerance test	IEC 60601 test conditions	Appropriateness level
Conductivity RF electromagnetic field IEC 61000 – 4 – 6	3 Vrms 150 kHz ~ 80 MHz	3 Vrms
Radioactivity RF electromagnetic field tolerance IEC 61000 – 4 – 3	10 V/m 80 MHz ~ 2.7 GHz scope	10 V/m

13

Specifications

- **HNT-1**

Intraocular Pressure Measurement Mode

Intraocular Pressure Measurement (AT3D (X, Y, Z), AT2D(X, Y), MT(Manual))

Measurable range	0~60mmHg, SPC30/60mmHg
Measurement Accuracy	±5mmHg
Measurement value	1mmHg step (Average:0.1mmHg step)
Dimensions	514(W) x 262(D) x 435(H)mm
Weight	17.5kg

- **HNT-1P**

Intraocular Pressure Measurement Mode

Intraocular Pressure Measurement (AT3D (X, Y, Z), AT2D(X, Y), MT(Manual))

Measurable range	0~60mmHg, SPC30/60mmHg
Measurement Accuracy	±5mmHg
Measurement value	1mmHg step (Average:0.1mmHg step)
Dimensions	514(W) x 262(D) x 435(H)mm
Weight	18.5kg

Cornea Thickness Measurement Mode

Pachymetry Measurement (AT3D (X, Y, Z), AT2D(X, Y), MT(Manual))

Measurable range	150~1300um
Measurement Accuracy	±5um
Measurement value	1um step

• **HNT-1/1P**

Data Memory

Measured value of ten(10) times amount for each left/right eye.

Hardware specification

Built-in printer	Thermal Line printer
Power saving function	As stopping to measure for about 1/3/5minutes, the main power is shut, it returns as pushing button.
Monitor	TFT LCD Color IPS Touch Panel of 7" (800x480)
Electrical Power	AC100 ~ 240V, 50/60Hz
Current	1.0 ~ 0.7A
External I/O	RS-232C (in/out)

14

Accessories

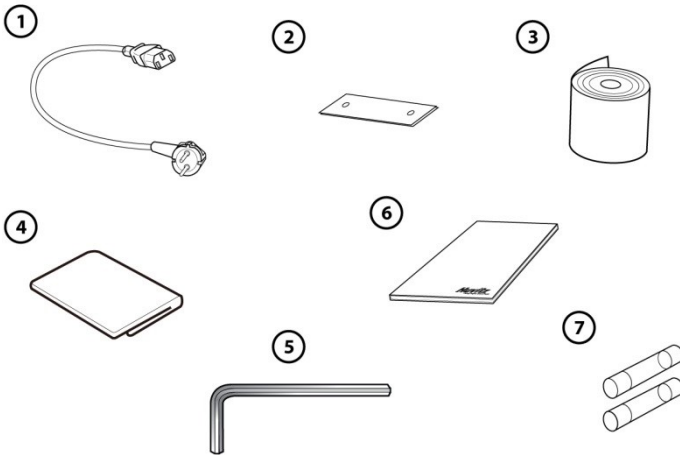

- ① Power cable1 unit
- ② Chin rest Paper100 sheet
- ③ Printer Paper2 rolls
- ④ Dust Cover1 Piece
- ⑤ Wrench(2.5mm)1 Piece
- ⑥ Operation's Manual1 volume
- ⑦ Spare Fuse (250V / 3.15A)2 units

✓ Accesories can be purchased separately. Please contact your local Huvitz representative or Huvitz customer service.